



MICROPACK
FIRE & GAS

FDS301

VISUAL FLAME DETECTOR

SAFETY & TECHNICAL
MANUAL

Ref: 2200.5009





HELP US TO HELP YOU

Every effort has been made to ensure the accuracy in the contents of our documents; however, Micropack (Engineering) Ltd can assume no responsibility for any errors or omissions in our documents or their consequences.

Micropack (Engineering) Ltd would greatly appreciate being informed of any errors or omissions that may be found in our documents. To this end we include a form, given in Appendix B, for you to photocopy, complete and return to us so that we take the appropriate action. **Thank you.**

TABLE OF CONTENTS

1		Introduction	4
	1.1	Features	4
	1.2	Visual Flame Detection	4
2		Safety Instructions	5
	2.1	Warnings	5
	2.2	Cautions	5
	2.3	VDS EN54 part 10 Limitations of use	6
	2.4	Important Safety Notices	6
3		Installation	8
	3.1	Detector Enclosure	8
	3.2	Mounting & Orientation	9
	3.3	Wiring Procedure	11
	3.3.1	4-20mA Output	12
	3.3.2	Relay Output	14
	3.4	Installation Checklist	15
	3.4.1	Mechanical	15
	3.4.2	Electrical	16
4		System Design Guidelines	17
	4.1	Earthing & Screening Requirements	17
	4.2	Power Supply	17
	4.3	RS485 Communications	17
	4.4	HART Protocol	18
	4.5	Cable Selection	18
	4.5.1	DC Power	19
	4.5.2	Video	20
	4.5.3	RS485 Communication	20





5	Application Guidelines	21
5.1	Positioning Requirements	21
5.2	Detection Coverage	22
5.3	Exposure to Flare Radiation	22
5.4	Optical Contamination	22
5.5	Enclosed Areas	23
5.6	Detector Sensitivity	23
6	Maintenance and Commissioning	24
6.1	Procedure	24
6.2	Functional Testing	26
7	Fault Finding	27
7.1	Removal of the Electronics	27
7.2	Replacement of the Electronics	27
7.3	Diagnostics	27
7.4	LED Indication	28
7.5	Power Fault	29
7.6	Live Video Images	29
8	Technical Specification	30
8.1	Electrical Specification	30
8.2	Mechanical Specification	31
8.3	Environmental Specification	31
8.4	Certification and Approvals	32
8.5	Operating Specification	32
Appendix A	Acronyms, Terms & Abbreviations	33
Appendix B	Help us to help you	34
Appendix C	IEC 61508 Failure Rate Data	35
Appendix D	FDS301 Field of View	36



1 Introduction

The Micropack Colour FDS301 is a combined flame detection and video surveillance system utilising unique real time video based flame detection technology developed by Micropack. The flame detection algorithms are capable of discriminating between genuine fire conditions and other radiant sources.

1.1 Features

<p>Live Video</p> <p>A live colour video image is available from each detector; this allows information about the protected area to be displayed on a monitor in the control room, providing the operator with a visual feedback of an event, which can reduce response time.</p>	<p>Immunity & Discrimination</p> <p>The detector is immune to common sources of unwanted alarms such as hot work (e.g. grinding and welding), Hot CO2 emissions (such as turbine exhausts) and Flare Radiation.</p>
<p>Robust and Reliable</p> <p>The detector has been designed to tolerate extreme environmental conditions experienced offshore or onshore.</p>	<p>Detection Coverage</p> <p>The detector is sensitive to fires of n-heptane 0.1m² at up to 44m within a 90° Horizontal field of view.</p> 
<p>SIL Capability</p> <p>The detector has been certified IEC 61508 SIL 2.</p> 	<p>Sensitivity</p> <p>The sensitivity of the detector is preset and no changes in sensitivity are required.</p> 

1.2 Visual Flame Detection

The detector operates 'stand alone' or can be integrated with an FM Approved control system. Detectors are typically located throughout the installation in order to achieve specific detection coverage and ensure that site performance requirements are met. Each detector is capable of providing live video images and fire alarm/fault signalling to the control equipment. Each detector incorporates within a single unit an imaging device, digital signal processing hardware, and firmware algorithms to process live video images and recognise flame features.



2 | Safety Instructions

For the correct and effective use of this equipment, to maintain safety and avoid hazards it is essential that you read and understand these instructions fully, act accordingly BEFORE installing, operating or maintaining the equipment.

PAY ATTENTION TO ALL SAFETY WARNINGS AND CAUTIONS

2.1 Warnings

This equipment is certified and intended for use in potentially hazardous areas. Install and use the equipment in accordance with the latest regulations.

For European (ATEX) installations IEC/EN60079-14 'Electrical Installations in Hazardous Areas' and IEC/EN 60079-17 'Inspection and Maintenance in Hazardous Areas' should be strictly observed.

For installations in North America the National Electrical Code (NEC) should be strictly observed.

In other countries the appropriate local or national regulations should be observed.

The equipment must be properly earthed to protect against electrical shock and minimise electrical interference.

Do not drill holes in any housing or enclosure as this will invalidate the explosion protection. Ensure that the enclosure lid is fully tightened and locked into position before energising the equipment.

Do not open the enclosure in the presence of an explosive atmosphere.

All permits and proper site procedure and practices must be followed and the equipment must be isolated from the power supply before opening the enclosure in the field.

Operators must be properly trained and aware of what actions to take in the event of a fire being detected.

Cable to be used for installation is to be selected with a temperature rating of greater than 25 degrees Celsius above the maximum ambient temperature.

The metric cable entries are fitted with an internal stop. This will result in threads of the cable gland being visible. Do not over tighten.

2.2 Cautions

Use only approved parts and accessories with this equipment.

Do not attempt to replace the window as the glass and the front cover are individually matched pairs to meet the stringent requirement of the Hazardous area certification.

The threaded portions of the detector are flame paths. These threads and the flame paths around the window are not to be repaired.

To maintain safety standards, commissioning and regular maintenance should be performed by qualified personnel.

2.3 VDS EN54 part 10 Limitations of use

The FDS301 is not approved for use in Oxygen-enriched atmospheres.

As the FDS301 responds to visible flame the FDS301 cannot be used in locations where flare stacks are within its field of view without triggering alarms.

The FDS301 is unable to detect fires that are invisible to the naked eye, such as those using pure hydrogen, methanol and sulphur as fuel.

The sensitivity of the FDS301 is reduced by obscurants such as smoke, fog and other airborne particulates. The FDS301 may be blinded by extremely dense obscurants.

Arc welding should not take place within 1 m of the FDS301.

The “optical fault” must be disabled for applications where there is no light present eg. Cellar or Chimney stack.

2.4 Important Safety Notices

Pay attention to the guidelines given throughout this document.

If in any doubt about the instructions listed within this manual then please contact Micropack (Engineering) Ltd. Micropack (Engineering) Ltd takes no responsibility for installation and/or use of its equipment if this it is not in accordance with the appropriate issue and/or amendment of the manual. Micropack (Engineering) Ltd reserve the right to change or revise the information contained herein without notice and without obligation to notify any person or organisation of such action.

Only those parameters and configurations highlighted with the FM diamond () have been tested and approved by Factory Mutual.

Warning

Do not open the detector assembly in a hazardous area when power is applied. The detector contains limited serviceable components and should never be opened except by trained personnel.

Caution

The wiring procedures in this manual are intended to ensure functionality of the device under normal conditions. Due to the many variations in wiring codes and regulations, total compliance to these ordinances cannot be guaranteed. Be certain that all wiring complies with all local ordinances. If in doubt, consult the authority having jurisdiction before wiring the system. Installation must be done by trained personnel.

Caution

To prevent unwanted actuation or alarm, extinguishing devices must be inhibited/isolated prior to performance testing or maintenance.

Caution

SIL 2 capability is only confirmed for 4-20mA output configuration of the FDS301 visual flame detector.

INSTALLATION

Detector Orientation

Detectors should be mounted with the earth stud/status led directly below the lens to ensure the 90° horizontal field of view is achieved (see section 3.2 and 5.2 of this document).

Detector Positioning

Detectors should be positioned to provide the best unobstructed view of the area to be protected. (see section 5.2 of this document).

The following factors should also be taken into consideration:

- Identify all high risk fire ignition sources. Ensure that enough detectors are used to adequately cover the hazardous area.
- Locate and position the detector so that the fire hazard(s) are within both the field of view and detection range of the device.
- For best performance, the detector should be mounted on a rigid surface in a low vibration area. (see section 5.1 of this document).
- Extremely dense fog or blizzard conditions could eventually block the vision of the detector. (see section 5.4 of this document).
- For indoor applications, if dense smoke is expected to accumulate at the onset of a fire, mount the detector on a side wall (approximately 1 metre, 3 feet) down from the ceiling.
- The FS301 flame simulator can be used to verify correct detector positioning and coverage (see section 6.2 of this document).
- The FDS301 has one sensitivity setting, this is factory set, and no changes can be made to set-up except by fully trained Micropack engineers.
- The detector carries out continuous internal hardware diagnostic testing to ensure correct operation is relayed to the control system. It can also be set to indicate dirty optics if this function is switched on. The detector should be subjected to a background light level of at least 1 LUX in every 16 hour period for 1 hour.
- The FDS301 is not designed to annunciate diagnostic failures of signal returns via external wiring. Control systems and fire panels generally have fault monitoring for such an eventuality.





3 Installation

The FDS301 design has been developed to allow simple installation. The detector comprises two key components, the detector enclosure and the detector internal assembly. The detector assembly located in the front of the enclosure should not be removed except by trained personnel. Unauthorised removal or disassembly of the detector assembly will invalidate the warranty. Only the rear end cap can be removed for terminal access.

3.1 Detector Enclosure

The detector electronics are housed in an enclosure certified for use in a hazardous areas. For the exact certification and conditions of use see certification label on the device, or the example drawing below:

 <p>Micropack ABERDEEN, SCOTLAND, AB12 4RR TYPE: FDS301 SERIAL No: <input type="text"/> Year: <input type="text"/> ENTRY: M25 <input type="checkbox"/> 1/2" NPT <input type="checkbox"/> Single <input type="checkbox"/> M20 <input type="checkbox"/> 3/4" NPT <input type="checkbox"/> Dual <input type="checkbox"/></p>		<p>EN54-10 Class 1</p> <div style="border: 1px solid black; padding: 5px; width: 40px; margin: 0 auto;">VdS</div> <p>G 215023 Angle of reception 64°</p>	<p>CE 1725  II 2 G Ex db IIC T4</p> <p>AMBIENT: -60°C +85°C FM07ATEX 0033 IECEX FME 07.0002 Maximum Voltage: 30VDC Maximum Current: 700mA</p>	<p>TYPE 4, IP66 Class I DIV 1 GROUPS B,C,D,T4 AMBIENT: -60°C +85°C Class I Zone 1 AEx/Ex db IIC T4 AMBIENT: -60°C +85°C DO NOT REPAIR FLAME PATHS SEAL CONDUIT WITHIN 18" OF ENCLOSURE ENTRANCE</p>	<div style="border: 1px solid black; padding: 5px; width: 60px; margin: 0 auto;">  3260 APPROVED </div>
<p>WARNING: DO NOT OPEN WHEN EXPLOSIVE ATMOSPHERE MAY BE PRESENT WARNING: REFER TO FDS301 TECHNICAL MANUAL 2200.5009 BEFORE INSTALLING OR MAINTAINING THIS UNIT</p>					

The enclosure comprises the front enclosure cover (including the faceplate window), the rear enclosure cover, the enclosure body (with certification label), and the mounting bracket.



3.2 Mounting & Orientation

The mounting bracket allows the detector's vertical orientation to be adjusted from 0 to 45°, and allows a horizontal rotation of +/-45°.

Figure 1: Detector Mounting Bracket & Orientation

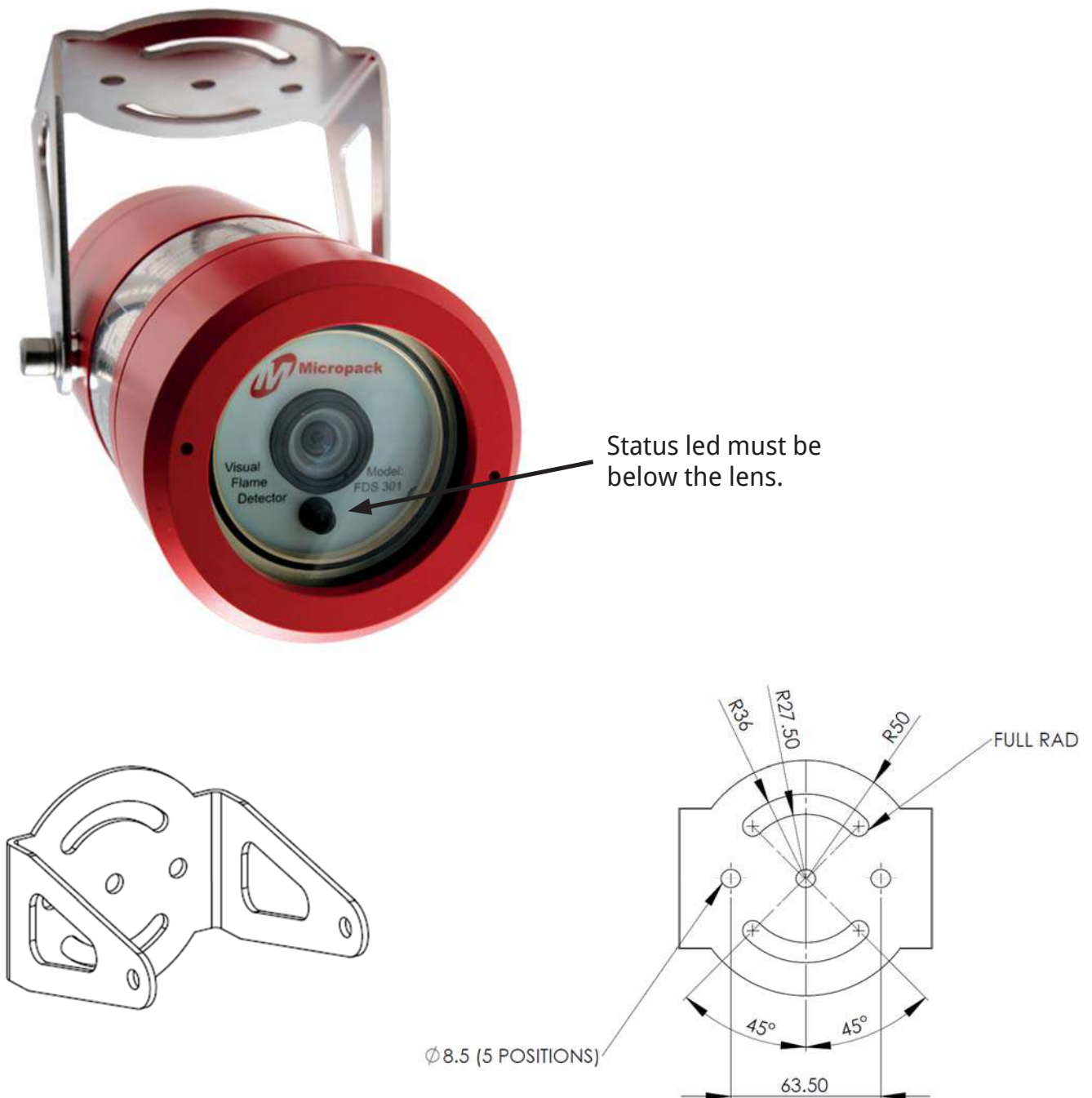



Figure 2: FDS301 Ceiling Mount

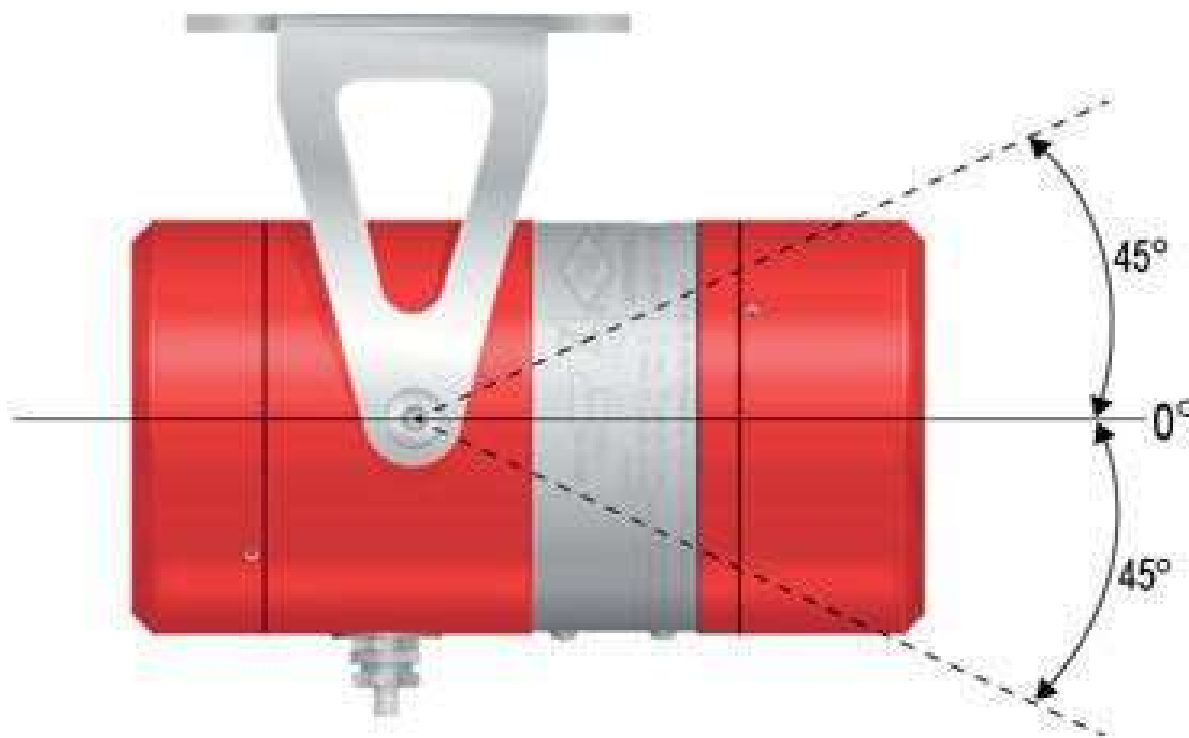
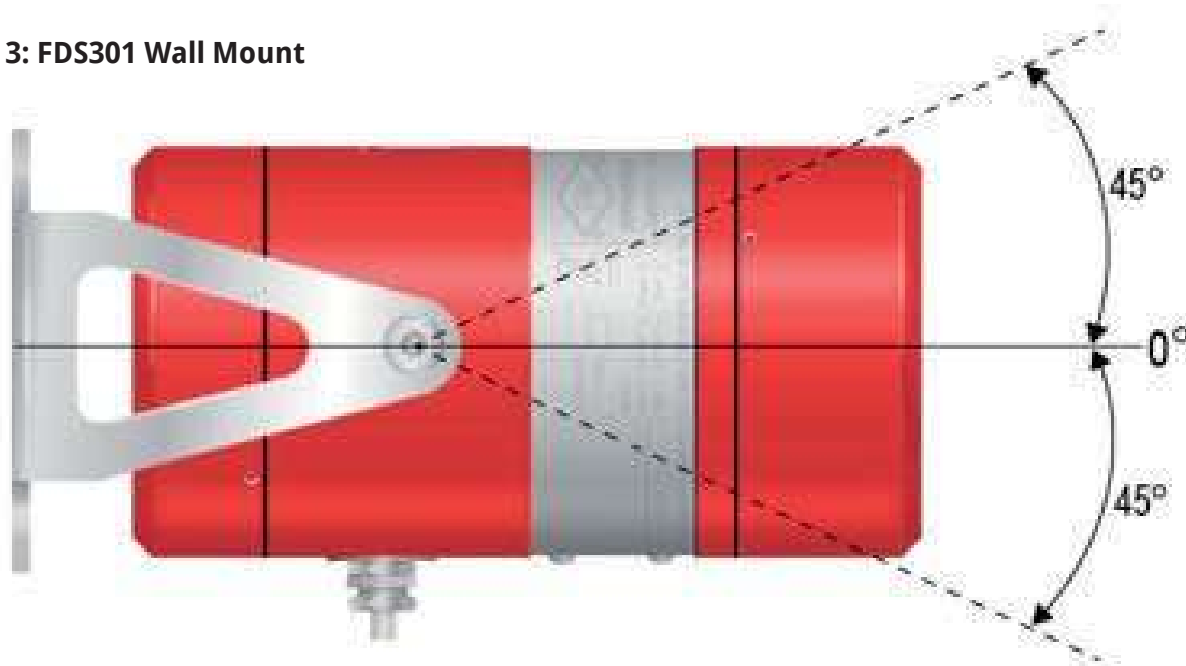

Figure 3: FDS301 Wall Mount



Firm, vibration free mountings are essential for trouble free operation of optical systems and the detector should be fixed to a rigid mounting. When mounting on a wall in this orientation allow for the cable gland and cable as this may restrict the downward rotation of the detector.



3.3 Wiring Procedure

The wiring terminals are located in the rear section of the detector enclosure and are accessible by removal of the end cap.

The front section of the enclosure should only be accessed by trained personnel.

The terminal schematic (figure 4) detailed below shows the view looking inside the detector following removal of the end cap. The terminals are shown numbered to the right of the drawing.

Figure 4: Terminal Schematic

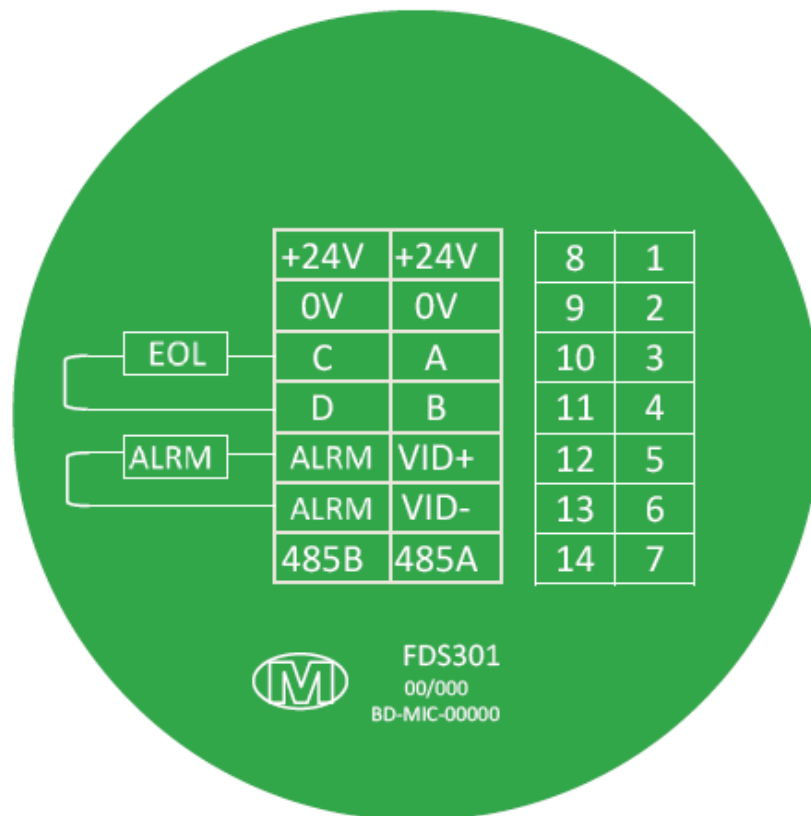

The detector has two types of alarm output available simultaneously

- 4-20mA (source)
- Relay (Alarm & Fault)

Listed below are wiring options dependant on the functional requirements of the detector.

Note: Information below describes how to access RS485 communication by reversing the polarity of the power when there is no dedicated RS485 pair. This operation will disable the signal return to the control system whilst enabled. Care should be taken after using this facility to return the detector to normal operation.

3.31 4-20mA Output

The following wiring connection diagrams show options for wiring the detector when configured in 4-20mA mode.

Figure 5: 3 Pair Termination

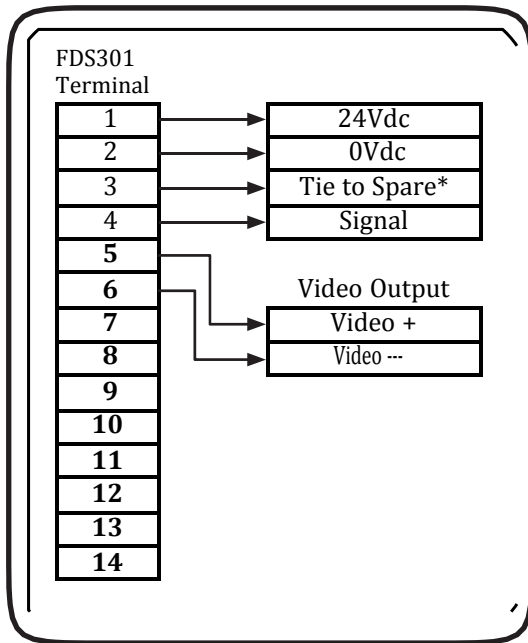

Figure 6: 2 Pair Termination

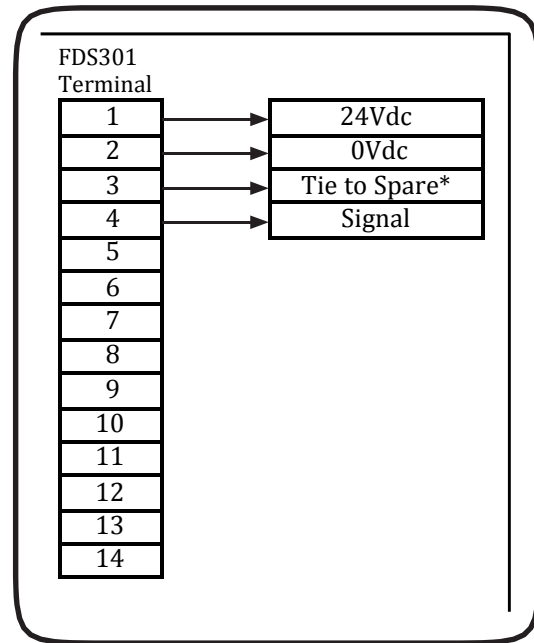

Figure 7: 3 Wire Termination

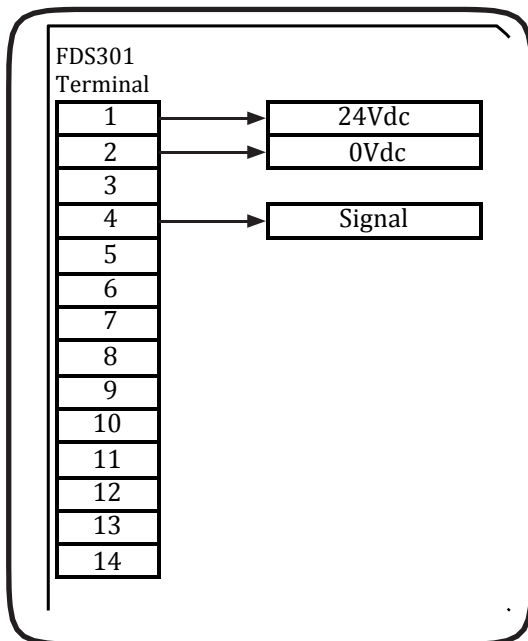
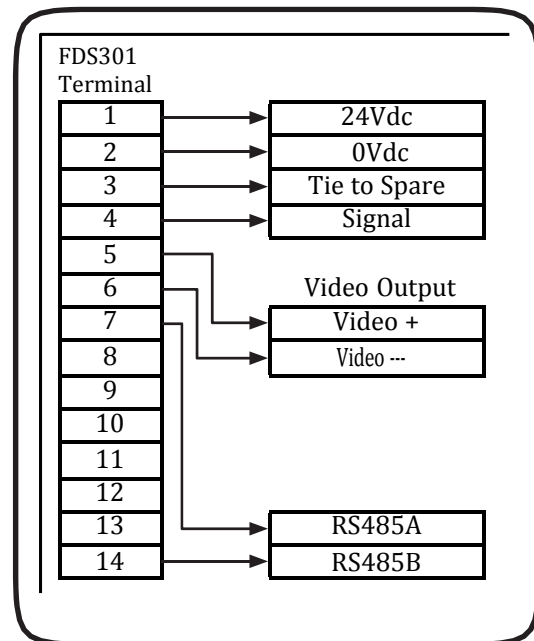

Figure 8: 4 Pair Termination



*Tied to spare terminal at control panel to allow RS485 communication with detector.

Information for wiring in the 4-20mA mode listed in figures 5 to 8 on previous page:

- 3 Pair Termination: Fully functional detector with continuous video and 4-20mA alarm output. Reversal of polarity across terminals 1 & 2 will enable Micropack RS485 communication.
- 2 Pair Termination: 4-20mA output only with reversal of polarity across terminals 1 & 2 enabling Micropack RS485 communication.
- 3 Wire Termination: Retrofit application where only 3 wires are available.
- 4 Pair Termination: Fully functional detector with continuous video, 4-20mA alarm output and connected Micropack RS485 communication.

Micropack RS485 communication should only be accessed by trained personnel.

Table 1: Current Level Output Indicators – Default Factory Values with a tolerance of +/- 1mA

Current Output	Event
0mA	Power/Detector Fault
2mA	Optical Fault
5mA	Healthy
18mA	Alarm
21mA	Over-range

Alarm Relay

A further feature of the FDS301 flame detector when configured in 4-20mA mode is that an alarm relay is available if required. The alarm relay contact closes on alarm and can be employed by connecting to terminals 3 and 13 of the device.

RS 485

It is highly recommended to always connect terminals 3 and 4 back to equipment room marshalling cabinet with the use of a twisted pair cable. This allow access to the RS485 from the safe area.

Figure 9: 4 Pair Termination with relay

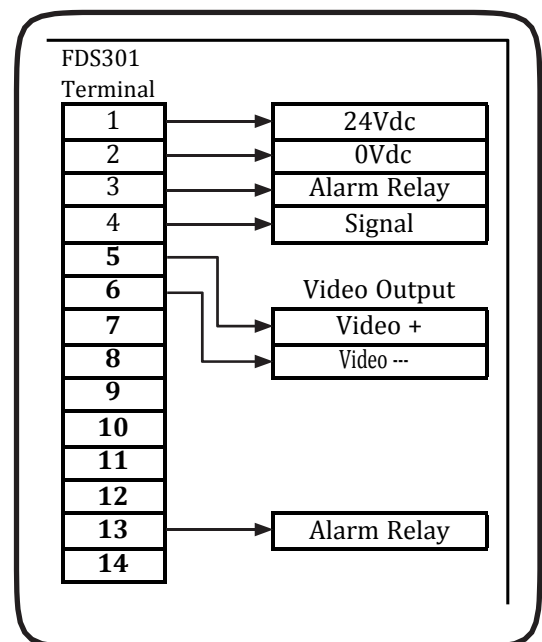

3.32 Relay Mode

The following wiring connection diagrams show options for wiring the detector when configured in relay mode.

Figure 10: 3 Pair Termination

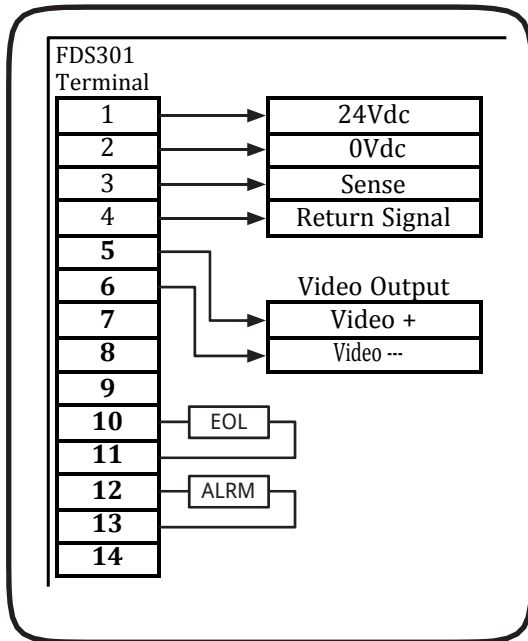

Figure 11: 2 Pair Termination

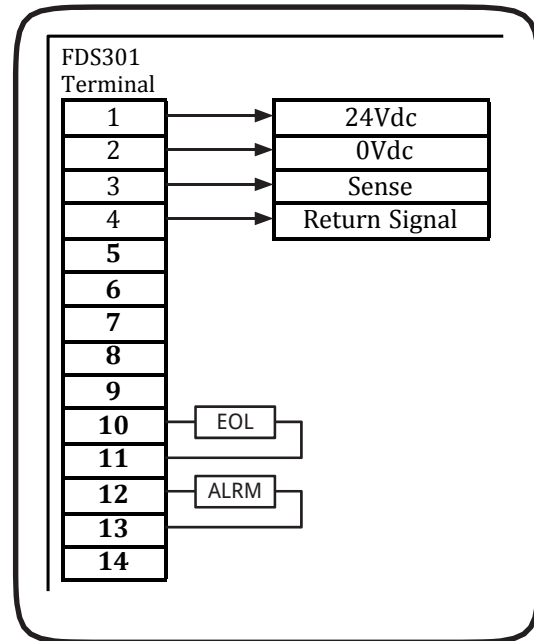
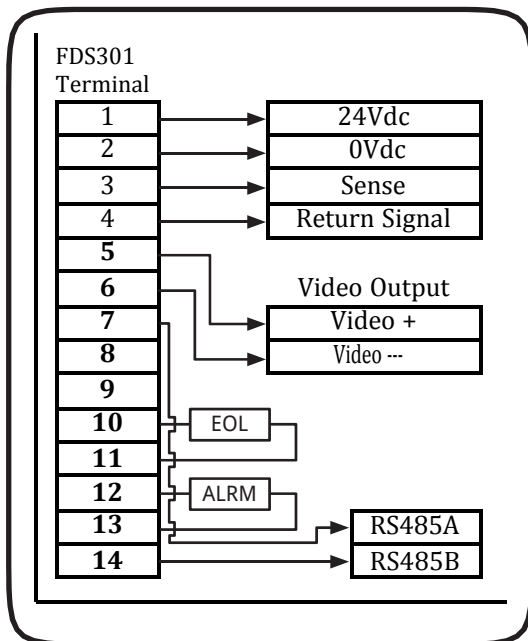

Figure 12: 4 Pair Termination



Information for wiring in the relay mode listed in figures 10 to 12 on previous page:

- 3 Pair Termination: Fully functional detector providing continuous video as well as alarm and fault relays. Reversal of polarity across terminals 1 & 2 will enable Micropack RS485 communication.
- 2 Pair Termination: Alarm and Fault relay only with reversal of polarity across terminals 1 & 2 enabling Micropack RS485 communication.
- 4 Pair Termination: Fully functional detector with continuous video, alarm and fault relays as well as permanent Micropack RS485 communication connections.

Micropack RS485 communication should only be accessed by trained personnel.

EOL and Alarm resistor values defined by the client and the control system which the detectors are being integrated into.

3.4 Installation Checklist

Experience has shown that poor installation and commissioning practice may result in an unreliable fire detection system that is prone to malfunction and unwanted alarms, and at the same time fails to meet the site performance targets. Before installing the detector it is important to take into account where it is to be located and how it is to be mounted.

3.4.1 Mechanical

Notes	
	When locating the detector consideration should be given to maintenance access to the detector. The detector mounting should be secure and vibration free. It is advisable to check the detection locations, prior to fabrication of the mounting supports, as changes are frequently made during construction at site which can affect detector coverage. The installation should allow subsequent space for detector removal, for maintenance or repair, to be easily achieved.
1	The detector should be fixed to a stable supporting structure using the mounting bracket provided. The supporting structure must allow for horizontal adjustment of the detector orientation. The support structure should be in place prior to detector installation. Information on mounting is available from Micropack (Engineering) Limited.
2	The threaded flame path of the enclosure cover and body must be protected from damage during installation. Any such damage can destroy the validity of the enclosure.
3	The detector electronics shall be protected from mechanical damage and external sources of EMI such as X-rays, RFI and electrostatic discharge. The detector should not face directly towards the sun.
4	Fit the mounting bracket to the support structure using 8mm bolts (not provided). The detector (bracket) should be oriented to provide the desired coverage.
5	The detector enclosure body should be fitted to the mounting bracket. The bolts locate into the bracket. Twist the enclosure to locate the bolts; these are then tightened using a 6mm Allen key.
6	Ensure the detector is orientated such that the status led/earthing stud is directly beneath the lens.
7	Glanding should be carried out by trained personnel. The gland should be fitted in line with installation standards for potentially explosive atmospheres that is 5 full threads minimum with the IP seal washer fitted at the bottom of the thread. This sealing arrangement will result in a number of threads of the cable gland being visible. The gland should be torqued between 15 to 20 NM (11 to 15 lbf-ft).



3.42 Electrical

In order to maintain compliance with the EMC regulations it is essential the electrical installation be engineered correctly.

Notes	It is advisable to check the detection locations, prior to fabrication of the mounting supports, as changes are frequently made during construction at site. Detector cabling must be segregated from cables carrying high-speed data or high energy and/or high frequency signals and other forms electrical interference. The detector requires a clear unobstructed view of the local hazard. In order to avoid local obstructions, such as pipe-work and cable trays, a 2m helix should be allowed in the detector cabling. The detector should only be fitted just prior to commissioning the detector. Experience shows that the detector can be damaged due to cable testing operations (Insulation Tests, etc)
1	Isolate all associated power supplies. Ensure that they remain OFF until required for commissioning.
2	The threaded flame path of the enclosure cover and body must be protected from damage during installation. Any such damage can destroy the validity of the enclosure.
3	The electronics subassembly shall be protected from mechanical damage and external sources of EMI such as X-rays, RFI and electrostatic discharge.
4	The enclosures external earth stud should be connected to a local earth point.
5	Remove the blanking plug(s) from the enclosure body gland entries.
6	Fit approved cable glands.
7	Prepare the cable tails. The cable screens should be cut back to the crotch at the detector and insulated from contact with the enclosure or any other local earth. The twist in each pairs should be maintained to within 1" (25mm) of the termination. Cable tails should be 8" (200mm) long.
8	Where plastic junction boxes are used the cable screens (shield) should be maintained to within 1" (25mm) of the termination and fully insulated.
9	Where unscreened cables are used for panel wiring, then all cables must be suitably twisted into pairs and video cables should be segregated from other signal sources.
10	All cable screens (shield) should be connected to the local clean earth at the control panel. The screens and twisted pairs should be maintained to within 1" (25.4mm) of the terminations.



4

System Design Guidelines

The following guidelines are intended to assist with the electrical design and engineering of systems where it is intended that flame detectors will be used.

4.1 Earthing & Screening Requirements

It is important to ensure that the system is correctly connected to earth. Incorrect or poor earthing can adversely affect system operation and may result in poor video image quality.

The detector enclosure is to be connected to a local earth and the detector cable screens (shields) should be cut back to the crotch and not terminated within the detector. If the detector enclosure cannot be connected to a local earth then care should be taken to ensure the cable armour braid provides a suitable earth or that the enclosure earth stud (external) is separately connected to a suitable earth point using a single core 4mm² earth cable.

All detector cable screens should be connected to the local clean earth at the control panel. The screens (and twisted pairs) should be maintained to within 1" (25.4mm) of the terminations at the detector, within all junction boxes and at the control panel. Where unscreened cables are used for panel wiring, then all cables must be suitably twisted into pairs and video cables should be segregated from other signal sources.

4.2 Power Supply

The detector requires an absolute minimum supply voltage of 18V, as measured at the detector terminals. The system power supply voltage and power distribution should be arranged such that on the longest cable run the detector(s) has a supply voltage of greater than 18V.

4.3 RS485 Communications

RS485 communications can be accessed either directly via the detector specific terminals, or as previously stated, via terminals A&B (3&4) whilst the power supply polarity is reversed. Using Micropack Simple Apps software, the RS485 channel can be used to view and/or modify detector firmware, version, configuration or download recorded alarm video from SD card. Contact Micropack for Simple Apps software.

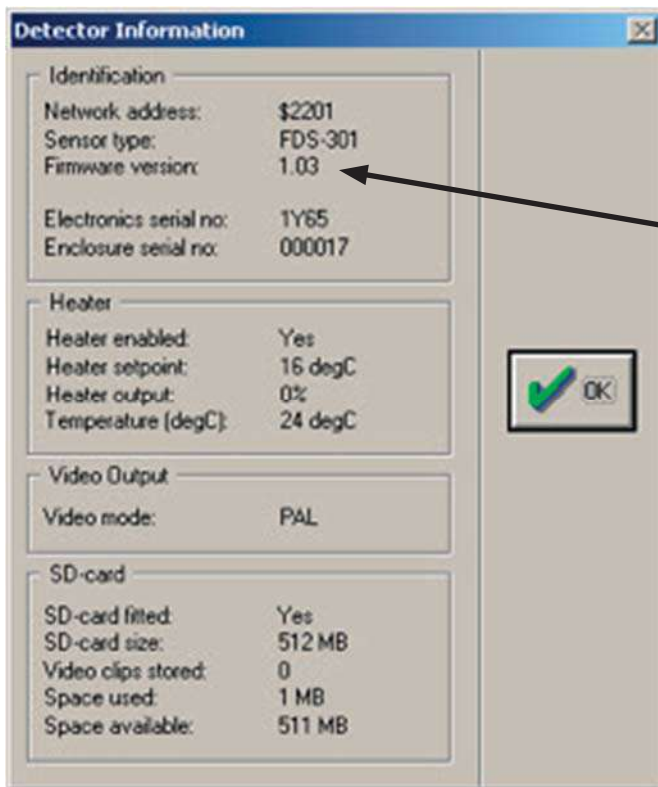

Figure 13: FDS301 Information

Firmware version

4.4 HART Protocol

Consult factory for further information regarding HART protocol.

4.5 Cable Selection

Cable to be used for installation is to be selected with a temperature rating of greater than 25° Celsius above the maximum ambient temperature.

The metric cable entries are fitted with an internal stop. This will result in threads of the cable gland being visible. Do not over tighten.

The installation and local regulations and standards determine the overall cable specification. This section specifies suitable cable characteristics to ensure correct operation of the flame detector. There are several different wiring methods available, as detailed in 3.3.1 and 3.3.2 of this manual.

4.5.1 DC Power

NOTE: Table 2 shows absolute maximums for cable lengths; try not to approach these values.

Table 2: Maximum Cable Lengths (24V supply)

Installation based on 24V nominal supply	Number of Flame Detectors	Maximum Power (W)	Maximum Cable Length (m) with 1.5mm ² Conductors (12Ω/km)	Maximum Cable Length (m) with 2.5mm ² Conductors (7.6Ω/km)
Detector	1	6	1,000	1,578
Detector & Heater	1	15	480	800

Table 3: AWG Conversions

Cross Sectional Area (mm ²)	American Wire Gauge (AWG)	Typical Conductor Resistance per km (3280 ft.) DC Ohms /km @ 20°C (approximate)
0.5	22	36
1	18	19
1.5	16	12
2.5	14	7.6

The overall performance and the transmission distance depend on the selected twisted pair cable. Individually screened twisted pairs offer better electrical immunity.

It is not necessary for the DC power cable to be a twisted pair or individually screened, a 2-core stranded cable with an overall screen is sufficient. The minimum conductor size is determined by the cable length, the number of Flame Detectors on each loop and the maximum allowed voltage drop at the last detector.

To prevent RS485 and Video common mode problems this is limited to a maximum of four volts (4V) on the negative supply (0V).

4.5.2 Video

The video cabling should be a twisted pair stranded cable with an overall screen. Where multi-core cables are used then individual screened twisted pairs are recommended. The cable should have the following characteristics:

Table 4: Video (Twisted Pair) Cable Characteristics

Cable Characteristic	Characteristic Impedance	Capacitance	Conductor Resistance	Attenuation @ 1MHz	Inductance
Nominal	150R	50nF/km	--	--	--
Absolute Limit	90R to 150R	100nF/km	150R	6dB	7mH/km

The maximum cable length is dependent on the cable manufacturer's attenuation specification, which is approximately proportional to conductor size.

The characteristic impedance of a transmission line is a function of the physical dimensions of the conductor and the permittivity of the dielectric (the insulation), at high frequencies this is approximately equivalent to:

$$Z_o(\wedge) = \sqrt{L | C}$$

L	= Cable Inductance (mH)
C	= Cable Capacitance (uF)
Zo	= Characteristic Impedance (Ohms)

Equation 1: Characteristic Impedance Calculation

For maximum performance the video output of the FDS301 is designed for differential twisted pair operation. For single ended output a Micropack VTP4 or differential to single ended balun should be used.

4.5.3 RS485 Communication

The RS485 communications cabling should be a twisted pair stranded cable with an overall screen. Where multi-core cables are used then individual screened twisted pairs are recommended. The cable should have the following characteristics:

Table 5: RS485 Communications Cable Characteristics

Cable Characteristic	Characteristic Impedance	Capacitance	Conductor Resistance	Attenuation @ 1MHz	Inductance
Nominal	120R	50nF/km	--	--	--
Absolute Limit	90R to 120R	100nF/km	120R	6dB	7mH/km

The maximum cable length is dependent on the cable manufacturers' attenuation specification, which is approximately proportional to conductor size. The characteristic impedance of a transmission line is the same as for the video above.



5 Application Guidelines

In considering the application of the detector it is important to know of any conditions that may prevent the detector from responding. The detector provides reliable response to visible flames within its field of view, and insensitivity to common false alarm sources. Solid obstructions or a direct view of intense light sources may result in a reduction in the coverage and/or a reduction in the detector sensitivity. Scaffolding or tarpaulins in the detector's field of view may reduce coverage. Contamination of the detector window may result in a reduction in sensitivity.

The detector provides a live colour video image for surveillance of the protected area. As with conventional video cameras the detector should not face directly towards the sun or a brightly lit scene. In such conditions the detectors automatic exposure control would darken the image in order to avoid overexposure; the resulting picture may be too dark for surveillance purposes. In the case of an offshore vessel or platform, the detector should ideally be placed facing inwards towards the plant and with minimal view of the horizon.

The detector has a horizontal field of view of 90° and a vertical field of view of 65°. The location and orientation of the detector in relation to the protected area determines the actual footprint. Achieving the desired coverage depends on congestion within the protected space, the location of the detector(s) and the distance of the detector from the hazard. It may be necessary to install more than one detector within an area in order to achieve adequate coverage.

The detector sensitivity, expressed as fire size at a distance, is determined visually by the apparent size of the fire. This is a function of the fuel source, how it is released and distance from the detector to the fire. The detector response time is relatively independent of fuel type and/or distance.

In common with other forms of flame detection the detector's sensitivity is reduced and potentially blinded by dense obscurants such as smoke, fog and other airborne particulates. The detector is insensitive to arc welding, however this should not be conducted within 1m of the detector.

5.1 Positioning Requirements

The following guidelines have been based on operational feedback, reflecting commonly experienced problems which can be traced to a failure to observe the following:

- Ensure the mounting position is free from vibration or movement.
- Prevent accidental knocking or forcing out of alignment.
- To ensure the best possible video image the detector should be facing away from the sun.
- Isolate as far as possible from local electrical interference sources.
- Ensure sufficient detection to achieve adequate coverage for all likely hazards.
- Minimise exposure to contamination of the detector face plate.
- Ensure ease of maintenance access to detector (i.e. direct, ladder or scaffold access).

All these issues are of crucial importance to a successful installation and they should be afforded great attention during the detailed design, construction and commissioning phases of the work.



5.2 Detection Coverage

Detector locations can be chosen from computer models or from site surveys. The detectors should be aligned to view the intended hazard taking into account any obstruction and congestion.

Figure 14: FDS301 Coverage & Field of View

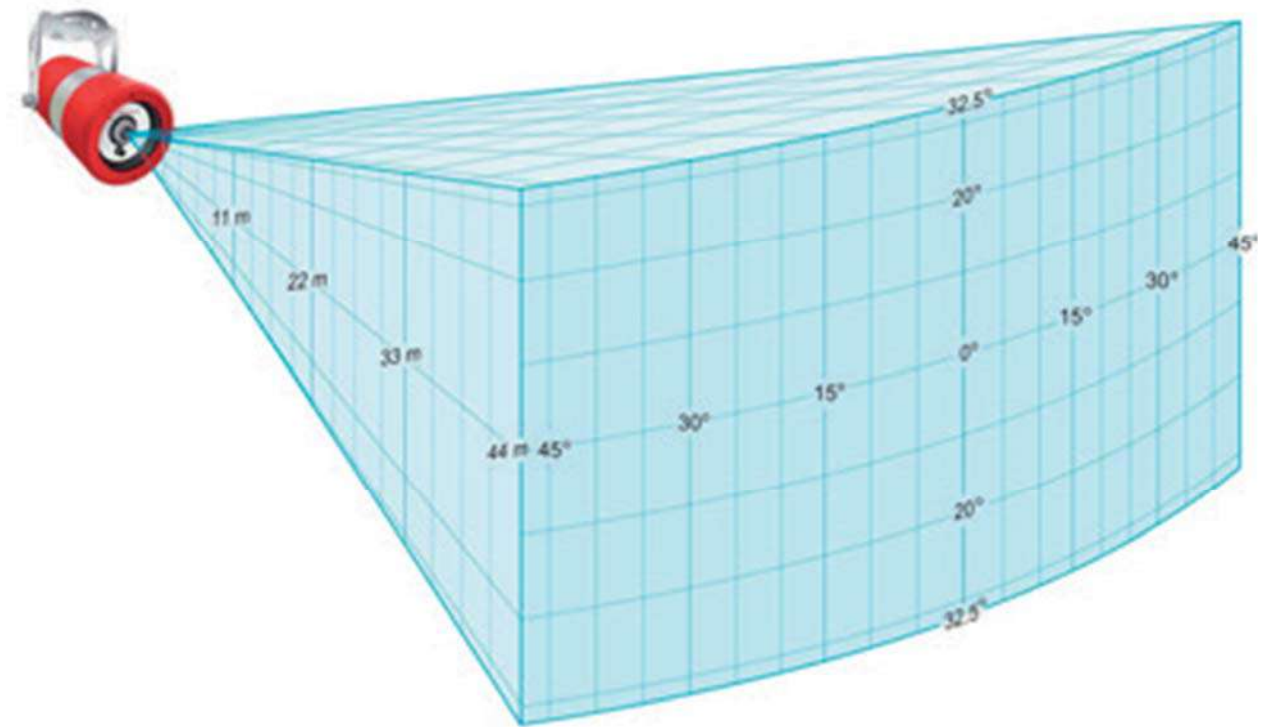

Software analysis of the actual detector coverage may be required to ensure adequate coverage of the hazards. This analysis can also be used to optimise the number of detectors.

5.3 Exposure to Flare Radiation

Flame detectors are frequently used where hydrocarbon fire hazards are expected; these are quite often processing plants where a flare stack is in use nearby. The detector should not have a direct view of the flare.

5.4 Optical Contamination

There are many sources of contamination such as oil, water (deluge water, rain and sea-spray), snow, ice, and internal misting. The design of the detector incorporates an internal heater in order to resist condensation and ice build-up. Excessive contamination of the detector faceplate may result in an increased maintenance requirement and potentially reduce the detector's sensitivity. Where detectors are mounted at low level, care should be taken to avoid contamination (such as water and oil) from equipment above the detector. Care should be taken in sighting the detector to minimise the likelihood of such contamination.

5.5 Enclosed Areas











In enclosed areas, if dense smoke is expected to accumulate at the onset of the fire, the detectors should be mounted 1 to 2m below the ceiling level.

5.6 Detector Sensitivity

The detector's response to a fire is a function of the fuel source and how it is released, fire size and distance, orientation to the detector and local ambient conditions. The typical figures are based on in-house tests except where marked with the FM logo these tests were conducted and certified by Factory Mutual. As with all tests the results must be interpreted according to the individual application taking into account all possible variables.

The detector sensitivity to different fuel sources is dependent on the apparent size of the flame, the detectors typical response is shown below (see table 6).

Table 4: Typical FDS301 Response Characteristics

Fuel	Fire Size	Distance	
Methane Jet Fire	3ft plume	30m (100 feet)	
Ethanol	0.3m x 0.3m pan	25m (85 feet)	
Diesel	0.3m x 0.3m pan	40m (130 feet)	
Crude Oil (heavy fuel oil) Pan Fire	0.5m x 0.5m pan	40m (130 feet)	
Wax Inhibitor (Clear 10) Pan Fire	0.3m x 0.3m pan	40m (130 feet)	
Anti-Foam (Surflo AF-300) Pan Fire	0.3m x 0.3m pan	40m (130 feet)	
Wood Stack	0.3m x 0.3m crib	40m (130 feet)	
n-Heptane Pan Fire	0.3m x 0.3m pan	44m (144 feet)	
n-Heptane Pan Fire in direct sunlight	0.3m x 0.3m pan	44m (144 feet)	
n-Heptane Pan Fire in modulated sunlight	0.3m x 0.3m pan	44m (144 feet)	
n-Heptane Pan Fire in the presence of modulated black body radiation	0.3m x 0.3m pan	44m (144 feet)	
n-Heptane Pan Fire in the presence of Arc welding	0.3m x 0.3m pan	44m (144 feet)	
n-Heptane Pan Fire in the presence of a 1000watt lamp	0.3m x 0.3m pan	44m (144 feet)	
Gasoline pan Fire	0.3m x 0.3m pan	44m (144 feet)	
JP4	0.6m x 0.6m pan	61m (200 feet)	
Silane	0.6m plume	13m(42 feet)	



6 Maintenance and Commissioning

6.1 Procedure

This maintenance schedule / commissioning procedure is intended for guidance only. The actual level of maintenance required will depend on the severity of the operating environment and the likelihood of damage or the rate of contamination from oil, sea spray, deluge system etc. It is advisable to regularly review maintenance reports and adapt the maintenance period to the operating environment.

Cautions:

Use only approved parts and accessories with this equipment.

Do not attempt to replace the window as the glass and the front cover are individually matched pairs to meet the stringent requirement of the Hazardous area certification. The threaded portions of the detector are flame paths. These threads and the flame paths around the window are not to be repaired.

To maintain safety standards, commissioning and regular maintenance should be performed by a qualified person.



Step	Periodic Inspection and Maintenance	Suggested Interval
1-6	General Inspection and maintenance of the detector and faceplate	6 monthly
6-14	Specific inspection and maintenance of the detector enclosure	12 monthly
16	Detector function testing	6 monthly
1-5 15-17	Commissioning Procedure	Post Installation
Step	Activity	Key Points
1	Detectors that require maintenance/ commissioning should be taken off line and inhibited. Detectors which require to be opened up will need to be isolated electrically.	Ensure that panel wiring and terminations associated with all units under test are in good order.
2	Ensure that detector mounting arrangements are secure and undamaged.	
3	Ensure that the detector enclosure is intact and undamaged.	
4	Ensure that all associated cables and glands are correctly made up, secure and undamaged.	
5	Clean the enclosure faceplate (outside) with a mild detergent solution and a soft cloth until the window is clear of all contamination. Wash the window thoroughly with clean water and dry with a clean lint free cloth or tissue.	Assess requirement for opening the enclosure, for maintenance or cleaning, follow steps 6 to 14
6	Open up the detector enclosure if required, by removing the enclosure cover. This exposes the enclosure flame path and detector lens.	Avoid damage to the flame path, faceplate and lens.
7	Clean the enclosure cover and body flame paths with a dry clean cloth to remove any contamination. If the flame path or threads are badly pitted the component should be replaced.	
8	Check the 'O' ring seal on the enclosure cover is not damaged or perished, replace as required. Note the ingress protection is compromised if the seal is not correct.	
9	Clean the enclosure faceplate (inside) with a mild detergent solution and a soft cloth until the window is clear of all contamination. Wash the window thoroughly with clean water and dry with a clean lint free cloth or tissue	
10	Non-setting waterproof grease should be evenly applied to the flame path on both the enclosure cover and body.	
11	Clean the detector lens. This should be done with a soft, dry and clean cloth.	Avoid touching the optics or electronics.
12	Clean the detector enclosure faceplate. Use a degreasing agent on the outside in order to remove deposits.	
13	The enclosure cover must be screwed on to a minimum of 5 full turns or until fully tight and secured using the locking screw provided.	
14	Reinstate the detector back into service.	
15	Ensure that inhibits are applied, then, using the flame test torch, function test the detector. Note the detector LED indicator, within the detector housing, changes colour to RED.	Check the complete display system for correct function and indication.
16	Isolate the power to the detector and ensure a fault is initiated within the control system. Check the mA output is indicating 0mA.	
17	De-isolate the detector and ensure the status LED indicates green. Reinstate the detector back into service.	



6.2 Functional Testing

The detector can be function tested using the FS301 Flame Simulator, which has been specifically designed to provide a convenient means of field testing the detector. Refer to the FS301 Flame Simulator user manual (ref. 2301.6042) for instructions on its use.

Failure of the detector to respond to the FS301 flame simulator should be reported to Micropack (Engineering) Limited (info@micropack.co.uk). It should be ensured that the flame detector and flame simulator are being used correctly in the first instance by referring to their manuals.

Detector/simulator returns along with a written statement describing any fault should be sent to the address listed below:

Micropack Engineering Repairs Ltd
c/o Norcott Technologies Ltd
Unit 1
Sunset Business Centre
Widnes
Cheshire
WA8 0QR





7 | Fault Finding

7.1 Removal of the Electronics

Warning - there are no user replaceable parts within the electronic module. Any attempt to repair or dismantle the electronic sub-assemblies will void the warranty. If any fault is suspected within the electronics module, the module is to be returned to Micropack for investigation and repair if required. Any faults should be reported to Micropack as per the instruction in section 6.2.

Removal of the electronics should only be performed by competent personnel.
The following is the procedure for removal of the electronic module:-

1. Loosen the allen screw that secures the lens cap to the housing.
2. Un-screw the lens cap assembly and remove.
3. Gently un-screw the three screws indicated on the label until they freely turn.
4. Please note these screws are not removable.
5. Grasp the two screws positioned at the bottom of the detector and pull the electronics module out of its housing.

7.2 Replacement of the Electronics

The following is the procedure for Installation of the electronic module:-

1. Insert the electronic module with the LED positioned at the bottom of the housing.
2. Rotate the module clockwise and anti-clockwise until the locating pins click into position.
3. Push the electronic assembly into the housing until the face plate is flush with the front of the housing. Note: This should take minimum force if the locating pins are in position.
4. Gently screw the three screws indicated on the label in until they bottom into their counter sinks Note: Do not over tighten.
5. Grease and replace the lens cap.
6. Tighten the lens cap Allen locking screw.

7.3 Diagnostics

It is impossible to provide fault diagnostics for every possible detector fault. In all cases it is advised that the following best practise is followed:

- Only make one change at a time (changing more than one thing makes diagnosis very difficult).
- Check the most obvious possible causes first.
- Work systematically through the problem.
- Keep good notes on the original problem, each step taken and the results observed.



7.4 LED Indication

The detector LED indicator is used to reveal the detector's current state, as shown below:

Figure 15: FDS301 Fascia - Status LED



Table 7: LED Status Diagnostic Chart

LED Colour	Status	Indicator
Green	Healthy	
Flashing Yellow/ Green	24V/0V Terminals Polarity Reversed	
Steady OFF	No Power/Major Internal Fault	
Steady Yellow	Fault	
Red	Alarm	



7.5 Power Fault

If the detector LED indicator is OFF then there may be a power supply fault, as shown below:

Figure 16: Power Supply Diagnostic Chart

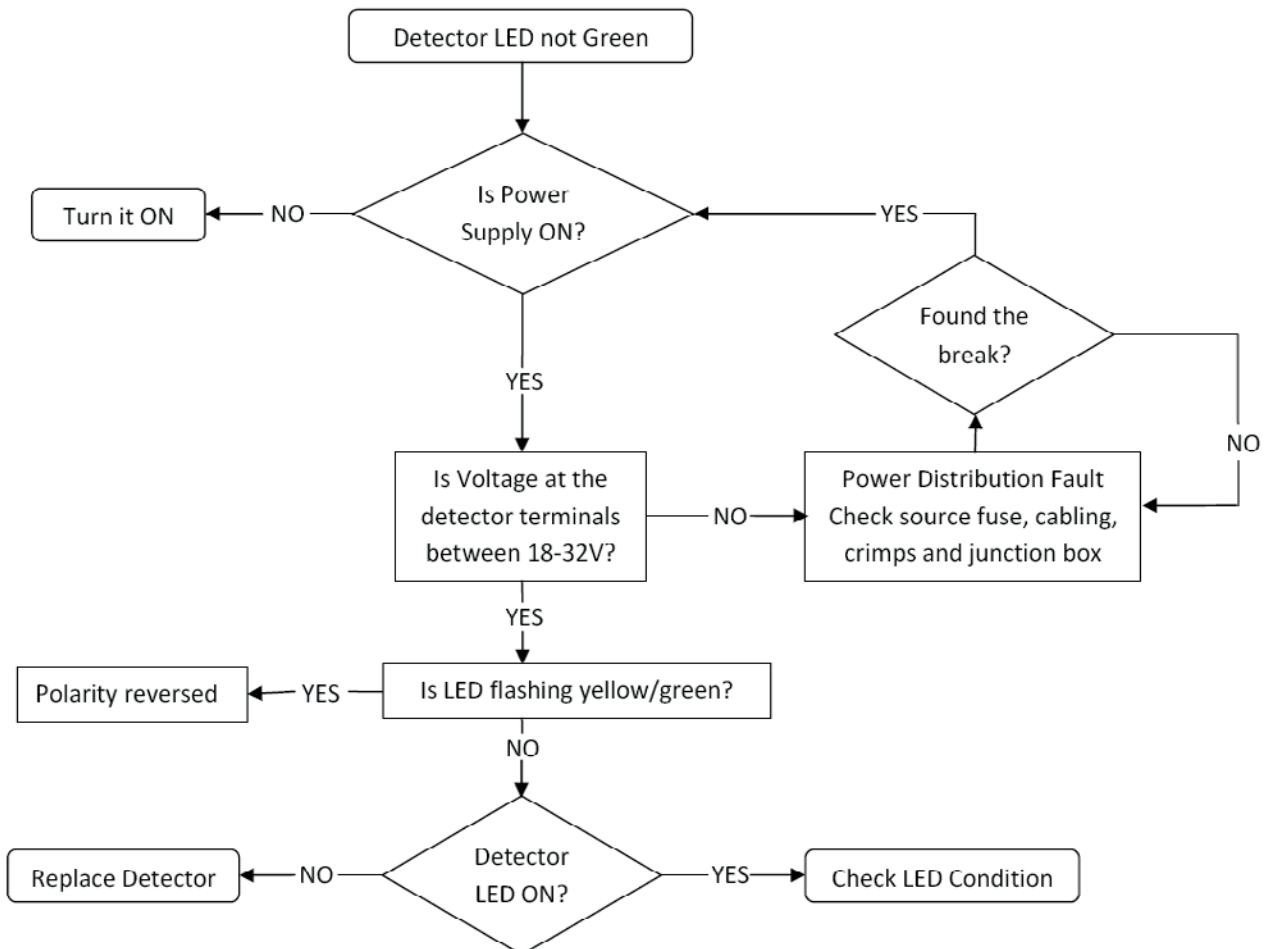

When investigating power supply faults it is important to check that all voltages are within the detectors operating range (18V to 32V) under full load conditions as the voltages measured under no load conditions can be misleading.

7.6 Live Video Images

Poor quality video is often a result of earth differentials, induced noise and/or inadequate screening. These issues require attention if video quality is a priority. Poor quality video does not affect the functionality of the FDS301 detector. Video can be verified from the detector using a portable viewing unit connected to the video output terminals. If there is video directly from the FDS301 then the control system must be examined for failures.



8 Technical Specification

8.1 Electrical Specification

Parameter	Units	Min	Max	Comment
Power Supply				
Supply Voltage outside Canada	V	18	32	Inc. ripple
Supply Voltage inside Canada	V	18	30	Inc. ripple
Supply Ripple	Vpk-pk	--	1	
Detector Power Consumption (no heater)	W	--	6	
Detector Power Consumption (inc. heater)	W	6	15	
Heater Power Consumption	W	0	12	
Detector shutdown voltage (low supply)	V		<17	
RS485 Transceiver				
Meets EIA-485 Standard Specification				
Line Termination Resistor	R	--	120	
Driver Differential Output Voltage	V	1.5	--	Typical 2.0
Driver Fan Out	Unit Loads	--	255	
Receiver Input Resistance	R	96K		
Receiver Unit Load			1/8	
Video Driver (Twisted Pair)				
Line Termination Resistor	R	--	150	Recommended
Driver Output Impedance	R	--	150	
Driver Output Voltage				
Terminated	Vpk-pk	1.8	2.3	Typical 2.1
Un-terminated	Vpk-pk	3.6	4.6	Typical 4.2



8.2 Mechanical Specification

Parameter	Units	Value	Comment
Enclosure			
Overall Dimensions	mm	100 Diameter x 200 Length	
Shipping Weight	Kg	2.5	6
Material		LM25 Alloy	316SS
Coating	Colour	Red Epoxy Coated Finish	
Cable Entries	mm/inches	M25, M20, ½ NPT, 3/4NPT	1 or 2 off
Terminal Wire Size	mm ²	2.5	
Ingress Protection	IP	66	
Mounting Bracket			
Support Fixings	mm	2 x M8	
Vertical Adjustment	Degrees	0 to 45	
Horizontal Adjustment	Degrees	0	Provided by support
Axial (horizontal) Rotation	Degrees	+/-45	

8.3 Environmental Specification

Parameter	Units	Min	Max	Comment
Operating Ambient Temperature	°C	- 60	+ 85	T4
Storage Ambient Temperature	°C	- 60	+ 85	
Relative Humidity	% RH	5	95	Non Condensing



8.4 Certification and Approvals

Parameter	Authority/Standard	Approval	Certificate
Hazardous Area Certification	ATEX	Ex II 2 G Ex db IIC T4 IP66	FM07ATEX0033
Hazardous Area Certification	NEC 505	Class 1 Zone 1 A Ex db IIC T4	3035984
Hazardous Area Certification	NEC 500	Class 1 Div 1 Groups B,C & D	3035984
Hazardous Area Certification	IEC Ex	Ex II 2 G Ex db IIC T4 IP66	FME 07 0002
Fire Service Listing	FM	Class 3260, 3600, 3615, 3800	3009845
CE Certification (Emissions)	York EMC	EN61000-6-3-201	9762TC2
CE Certification (immunity)	York EMC	EN50130-4+A1 1998+A2 2003	9762TC2
Functional Safety	Exida	IEC 61508:2000 Parts 1,2,3 SIL 2*	MP 080203 C001

8.5 Operating Specification

Parameter	Units	Min	Max	Comment
Detector Range (depth of field)	m	2	44	
Horizontal Field of View	Degrees	90	-	
Vertical Field of View	Degrees	-	65	
Detector Response Time	Seconds	4	30	
Power on reset delay	Seconds	5	30	
Optical Verification	-	-	-	Default - Off



Appendix A - Acronyms, Terms & Abbreviations

Term	Description
AC	Alternating Current
ATEX	Atmosphere Explosive
AWG	American Wire Gauge
BS	British Standard
CCTV	Closed Circuit Television
CE	European Commission (approval)
CO ₂	Carbon Dioxide
CSA	Canadian Standards Association
dB	Decibel
DC	Direct Current
EMC	Electromagnetic Compatibility
EN	European National (standard)
FM	Factory Mutual
FOV	Field of View
I or A	Electrical Current or Ampere
JB	Junction Box
Km	Kilometre
kW	Kilo Watt
LED	Light Emitting Diode
MEL	Micropack (Engineering) Ltd
mH	Milli Henry – Inductance
MOR	Meteorological Optical Range
NEC	National Electrical Codes
nF, pF	Nano Farad, Pico Farad – Capacitance
PC	Personal Computer (IBM PC Compatible)
R or Ω	Ohms (electrical resistance)
V	Voltage
Vs	Versus
W	Watts (Wattage)



Appendix B - Help us to help you

TO: QA Department Micropack (Engineering) Limited Fire Training Centre Schoolhill, Portlethen AB12 4RR Tel: +44 (0) 1224 784055 Fax: +44 (0) 1224 784056 Email: info@micropack.co.uk	From: Tel: Fax: Email:
I suggest the following corrections/changes be made to Section	
Marked up copies attached (as appropriate): Yes/No	
Please inform me of the outcome of this change: Yes/No	
For Micropack (Engineering) Limited :	
Action by: _____ Date: _____	
Response: _____ Date: _____	

Appendix C - IEC 61508 Failure Rate Data

Certified SIL 2 Capable

IEC 61508:2000 Parts 1, 2, 3

Using reliability data extracted from the exida Electrical and Mechanical Component Reliability Handbook the following failure rates resulted from the FDS301 FMEDA.



The useful lifetime of components contributing to dangerous undetected failure is approximately 50 years (Ref: Report No.: MP 08/02-03 R004 V1 R2).

Failure Category	Failure Rate (FIT)	
Fail Safe Undetected	10.3	
Fail Dangerous Detected	638.0	
Fail Detected (detected by internal diagnostics)	547.4	
Fail High (detected by logic solver)	19.6	
Fail Low (detected by logic solver)	71.0	
Fail Dangerous Undetected	76.0	
Residual Effect	114.9	
Annunciation Undetected	21.1	

Safe Failure Fraction (SFF): 91.2%

Proof Testing

Proof testing should be carried out on a yearly basis, showing a probability of failure on demand average (PFD_{AVG}) of 3.38E-04.

Step	Action
1	By-pass /inhibit the safety function and take appropriate action to avoid a false trip.
2	Clean window of detector using a soft cloth and detergent.
3	Perform a test of the FDS301 using the FS301.
4	Remove the by-pass/inhibit and restore normal operation.



Appendix D - FDS301 Field of View

Horizontal field of view to a 0.1 metre² N-heptane pan fire with an alarm response time of less than 10 seconds 100%=44 metres

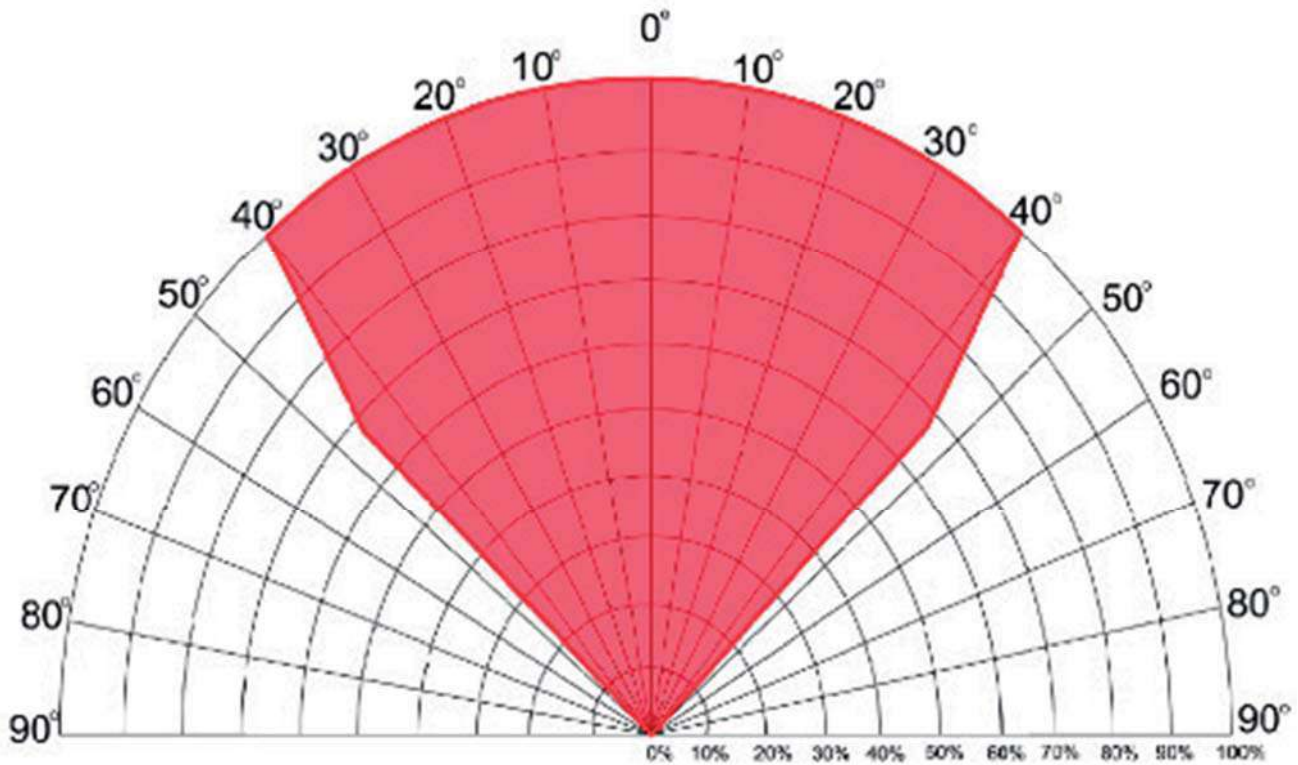

Horizontal field of view to a 0.1 metre² N-heptane pan fire with an alarm response time of less than 30 seconds 100%=44 metres

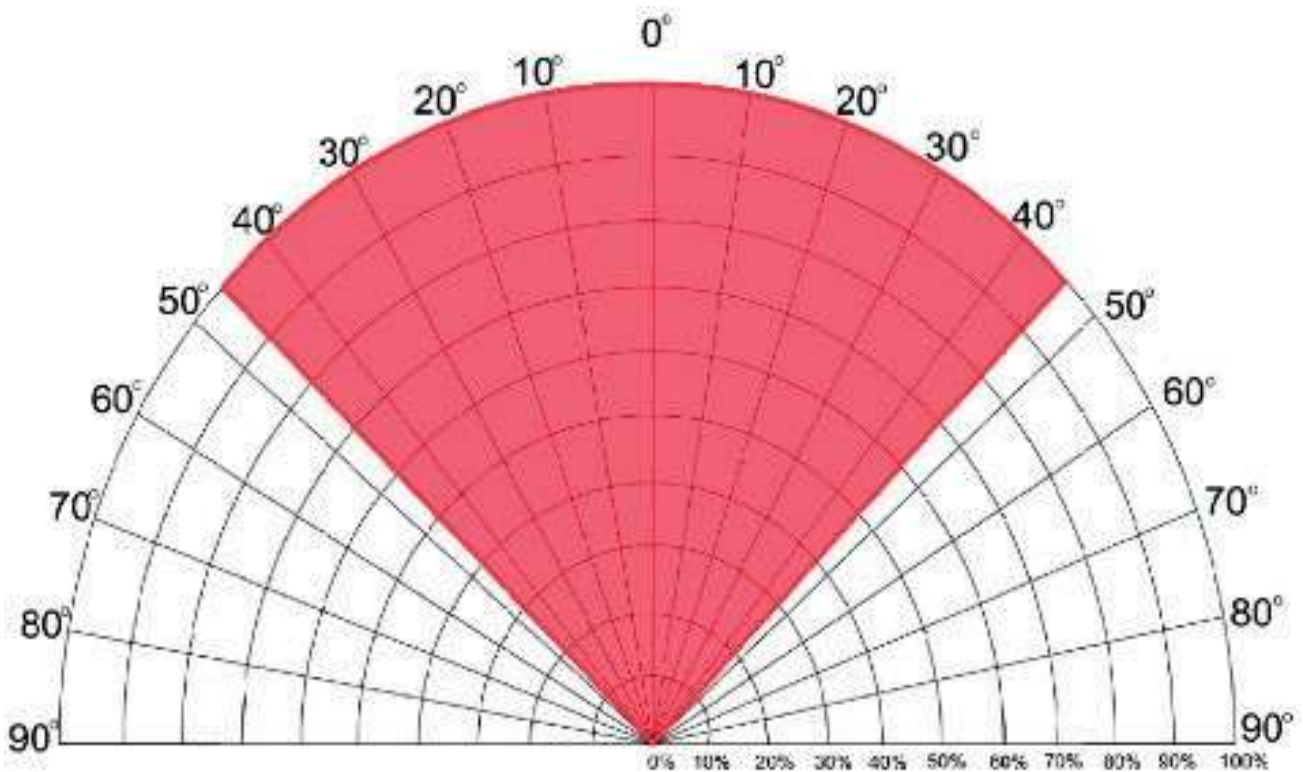



MICROPACK

FIRE & GAS



In the UK & Europe
MICROPACK (Engineering) Ltd
Fire Training Centre, Schoolhill,
Portlethen, Aberdeen AB12 4RR
Tel: +44 (0)1224 784055
Fax: +44 (0)1224 784056
Email: sales@micropack.co.uk
micropack.co.uk

In the Americas
MICROPACK Detection (Americas) Inc
1227 Lakecrest Court, Fort Collins,
Colorado, 80526
Tel: +1 970 377 2230
Fax: +1 970 377 2273
Email: info@micropackamericas.com
micropackamericas.com



Subject to modifications. © 2015 Micropack (Engineering) Ltd.