

SIEMENS



SIPART PS2 (6DR5...)

Electropneumatic positioners

Compact Operating Instructions

Edition

05/2017

Answers for industry.

SIEMENS

SIPART

Electropneumatic positioners SIPART PS2 (6DR5...)

Compact Operating Instructions

<u>Introduction</u>	1
<u>Safety instructions</u>	2
<u>Installing/mounting</u>	3
<u>Connecting</u>	4
<u>Commissioning</u>	5
<u>Service and maintenance</u>	6
<u>Technical data</u>	7
<u>Appendix</u>	8

6DR5...
With and without HART
With PROFIBUS
With FOUNDATION Fieldbus

Legal information

Warning notice system

This manual contains notices you have to observe in order to ensure your personal safety, as well as to prevent damage to property. The notices referring to your personal safety are highlighted in the manual by a safety alert symbol, notices referring only to property damage have no safety alert symbol. These notices shown below are graded according to the degree of danger.

⚠ DANGER
indicates that death or severe personal injury will result if proper precautions are not taken.

⚠ WARNING
indicates that death or severe personal injury may result if proper precautions are not taken.

⚠ CAUTION
indicates that minor personal injury can result if proper precautions are not taken.

NOTICE
indicates that property damage can result if proper precautions are not taken.

If more than one degree of danger is present, the warning notice representing the highest degree of danger will be used. A notice warning of injury to persons with a safety alert symbol may also include a warning relating to property damage.

Qualified Personnel

The product/system described in this documentation may be operated only by **personnel qualified** for the specific task in accordance with the relevant documentation, in particular its warning notices and safety instructions. Qualified personnel are those who, based on their training and experience, are capable of identifying risks and avoiding potential hazards when working with these products/systems.

Proper use of Siemens products

Note the following:

⚠ WARNING
Siemens products may only be used for the applications described in the catalog and in the relevant technical documentation. If products and components from other manufacturers are used, these must be recommended or approved by Siemens. Proper transport, storage, installation, assembly, commissioning, operation and maintenance are required to ensure that the products operate safely and without any problems. The permissible ambient conditions must be complied with. The information in the relevant documentation must be observed.

Trademarks

All names identified by ® are registered trademarks of Siemens AG. The remaining trademarks in this publication may be trademarks whose use by third parties for their own purposes could violate the rights of the owner.

Disclaimer of Liability

We have reviewed the contents of this publication to ensure consistency with the hardware and software described. Since variance cannot be precluded entirely, we cannot guarantee full consistency. However, the information in this publication is reviewed regularly and any necessary corrections are included in subsequent editions.

Table of contents

1	Introduction.....	9
1.1	Purpose of this documentation.....	9
1.2	Product compatibility.....	9
1.3	Purpose.....	10
1.4	Checking the consignment.....	10
1.5	Nameplates.....	11
1.6	Security information.....	12
1.7	Transportation and storage.....	13
1.8	Notes on warranty.....	13
2	Safety instructions.....	15
2.1	Precondition for use.....	15
2.2	Warning symbols on the device.....	15
2.3	Laws and directives.....	15
2.4	Conformity with European directives.....	16
2.5	Improper device modifications.....	16
2.6	Use in areas subject to explosion hazard.....	17
3	Installing/mounting.....	19
3.1	Basic safety instructions.....	19
3.1.1	Proper mounting.....	21
3.2	Mounting the linear actuator.....	22
3.3	Mounting the part-turn actuator.....	22
3.4	Using the positioner in a humid environment.....	22
3.5	Positioners subjected to fast acceleration or strong vibration.....	23
3.6	Installing option modules.....	26
3.6.1	Internal NCS module.....	27
4	Connecting.....	29
4.1	Basic safety instructions.....	29
4.1.1	Additional safety notes for PA and FF.....	33
4.2	Electrical connection.....	34
4.2.1	SIPART PS2 with and without HART.....	34
4.2.1.1	Basic electronics, 2/3/4-wire, with connection type 4-wire, connection diagram (with and without HART).....	35
4.2.2	SIPART PS2 with PROFIBUS PA.....	36
4.2.3	SIPART PS2 with FOUNDATION Fieldbus.....	36

4.2.4	Split range.....	37
4.2.5	Option modules.....	38
4.2.5.1	Alarm modules 6DR4004-6A and -8A.....	38
4.2.5.2	Position feedback modules 6DR4004-6J and -8J.....	39
4.2.5.3	SIA modules 6DR4004-6G and -8G.....	39
4.2.5.4	Mechanical limit switch modules 6DR4004-6K and -8K.....	40
4.2.6	Option device version M12 connector.....	41
4.2.6.1	M12 connector in basic device SIPART PS2 with and without HART.....	42
4.2.6.2	M12 connector in basic device SIPART PS2 with PROFIBUS PA.....	42
4.2.6.3	M12 connector in basic device SIPART PS2 with FOUNDATION Fieldbus.....	42
4.2.6.4	M12 connector for connection of the outputs of the alarm module 6DR4004-6A / -8A (-Z D55).....	43
4.2.6.5	M12 connector for connecting the outputs of the position feedback module 6DR4004-6J / 8J (-Z D53).....	43
4.2.6.6	M12 connector for connecting the external position detection system (-Z D54).....	43
4.2.6.7	M12 connector for connecting the outputs of the SIA module 6DR4004-6G /-8G (-Z D56).....	44
4.3	Pneumatic connection.....	44
4.3.1	Pneumatic connection for 6DR5..0/1/2/3.....	45
4.3.2	Pneumatic connection for 6DR5..5 and 6DR5..6.....	46
4.4	Restrictors.....	46
5	Commissioning.....	49
5.1	Basic safety instructions.....	49
5.1.1	Safety notes for operation with natural gas.....	51
5.2	Overview.....	51
5.3	Sequence of automatic initialization.....	52
5.4	Parameter.....	53
5.4.1	Overview of initialization parameters 1 to 5.....	53
5.5	Purge air switching.....	54
5.6	Commissioning linear actuators.....	54
5.6.1	Preparing linear actuators for commissioning.....	54
5.6.2	Automatic initialization of linear actuators.....	56
5.6.3	Manual initialization of linear actuators.....	58
5.7	Commissioning part-turn actuators.....	58
5.7.1	Preparing part-turn actuators for commissioning.....	58
5.7.2	Automatic initialization of part-turn actuators.....	59
5.7.3	Manual initialization of part-turn actuators.....	61
6	Service and maintenance.....	63
6.1	Basic safety instructions.....	63
6.2	Cleaning of the screens.....	64
6.2.1	Positioners with polycarbonate enclosure 6DR5..0, aluminum enclosure 6DR5..3, and flameproof aluminum enclosure 6DR5..5.....	64
6.2.2	Positioners with stainless steel enclosure 6DR5..2, flameproof stainless steel enclosure 6DR5..6, and narrow aluminum enclosure 6DR5..1.....	65
6.3	Maintenance and repair work.....	66
6.3.1	Repair/Upgrading.....	66

6.4	Return procedure.....	66
6.5	Disposal.....	67
7	Technical data.....	69
7.1	All device versions.....	69
7.1.1	Operating conditions.....	69
7.1.2	Pneumatic data.....	70
7.1.3	Construction.....	70
7.1.4	Controller.....	72
7.1.5	Certificates, approvals, explosion protection.....	73
7.2	Natural gas as actuator medium.....	75
7.3	SIPART PS2 with and without HART.....	76
7.3.1	Electrical data.....	76
7.3.2	Communication (HART).....	78
7.4	SIPART PS2 with PROFIBUS PA/with FOUNDATION Fieldbus.....	78
7.4.1	Electrical data.....	78
7.4.2	PROFIBUS PA communication.....	79
7.4.3	FOUNDATION Fieldbus communication.....	80
7.5	Option modules.....	80
7.5.1	Alarm module.....	80
7.5.2	Position feedback module.....	81
7.5.3	SIA module.....	82
7.5.4	Mechanical limit switch module.....	83
7.5.5	EMC filter module.....	84
7.5.6	Internal NCS modules 6DR4004-5L and 6DR4004-5LE.....	85
7.5.7	External position detection.....	85
7.5.7.1	Non contacting sensors 6DR4004-6N..0 and 6DR4004-8N..0.....	85
7.5.7.2	External position detection system C73451-A430-D78 and 6DR4004-1ES.....	86
8	Appendix.....	89
8.1	Certificates.....	89
8.2	Technical support.....	89
8.3	Accessory part sealing plug / thread adapter.....	90
8.3.1	Intended use of accessory part.....	90
8.3.2	Safety instructions for accessory part.....	91
8.3.3	Technical specifications of accessory part.....	91
8.3.4	Dimensional drawings of accessory part.....	92
	Index.....	95

Introduction

1.1 Purpose of this documentation

These instructions are a brief summary of important features, functions and safety information, and contain all information required for safe use of the device. Read the instructions carefully prior to installation and commissioning. In order to use the device correctly, first review its principle of operation.

The instructions are aimed at persons who install and commission the device.

To realize optimum performance from the device, read the complete operating instructions.

See also

Process instrumentation catalog (<http://www.siemens.com/processinstrumentation/catalogs>)

SIPART PS2 product information (<http://www.siemens.com/sipartps2>)

1.2 Product compatibility

The following tables describe compatibility between manual edition, device revision, engineering system and associated EDD.

HART

Manual edition	Comments	Device revision	Compatible version of device integration package	
05/2017	New device features	HART FW: 5.01.00 or higher Device revision 6 or higher	SIMATIC PDM V9.0	EDD: 23.00.00 or higher
			SIMATIC PDM V8.2 SP1	EDD: 23.00.00 or higher
			AMS Device Manager V12.0	EDD: 23.00.00 or higher
			SITRANS DTM V4.1	EDD: 23.00.00 or higher
			Field communicator	EDD: 23.00.00 or higher
01/2017	New device features	HART FW: 5.00.xx Device revision 5	SIMATIC PDM V9.0	EDD: 22.00.00 or higher
			SIMATIC PDM V8.2 SP1	EDD: 22.00.00 or higher
			AMS Device Manager V12.0	EDD: 22.00.01 or higher
			SITRANS DTM V3.1	EDD: 3.00.00 or higher
			Field communicator	EDD: 22.00.01 or higher

PROFIBUS PA

Manual edition	Comments	Device revision	Compatible version of device integration package	
05/2017	New device features	PROFIBUS PA FW: 6.00.00 or higher	SIMATIC PDM V9.0	EDD: 22.00.00 or higher
			SIMATIC PDM V8.2 SP1	EDD: 22.00.00 or higher
			SITRANS DTM V4.0	EDD: 22.00.01 or higher

FOUNDATION Fieldbus

Manual edition	Comments	Device revision	Compatible version of device integration package	
05/2017	New device features	FOUNDATION Fieldbus FW: 3.00.00 or higher Device revision 3	SIMATIC PDM V9.0	EDD: 3.00.00 or higher
			SIMATIC PDM V8.2 SP1	EDD: 3.00.00 or higher
			SITRANS DTM V4.0	EDD: 3.00.00 or higher

1.3 Purpose

The electropneumatic positioner is used for the continuous control of process valves with pneumatic drives in the following industries.

- Chemicals
- Oil and gas
- Energy production
- Food and beverages
- Pulp and paper
- Water/waste water
- Pharmaceutical industry
- Offshore plants

Operate the device according to the specifications in section "Technical data (Page 69)".

For additional information, refer to the operating instructions for the device.

1.4 Checking the consignment

1. Check the packaging and the delivered items for visible damage.
2. Report any claims for damages immediately to the shipping company.

3. Retain damaged parts for clarification.
4. Check the scope of delivery by comparing your order to the shipping documents for correctness and completeness.

 WARNING
Using a damaged or incomplete device Risk of explosion in hazardous areas. <ul style="list-style-type: none"> • Do not use damaged or incomplete devices.

1.5 Nameplates

Layout of the nameplate

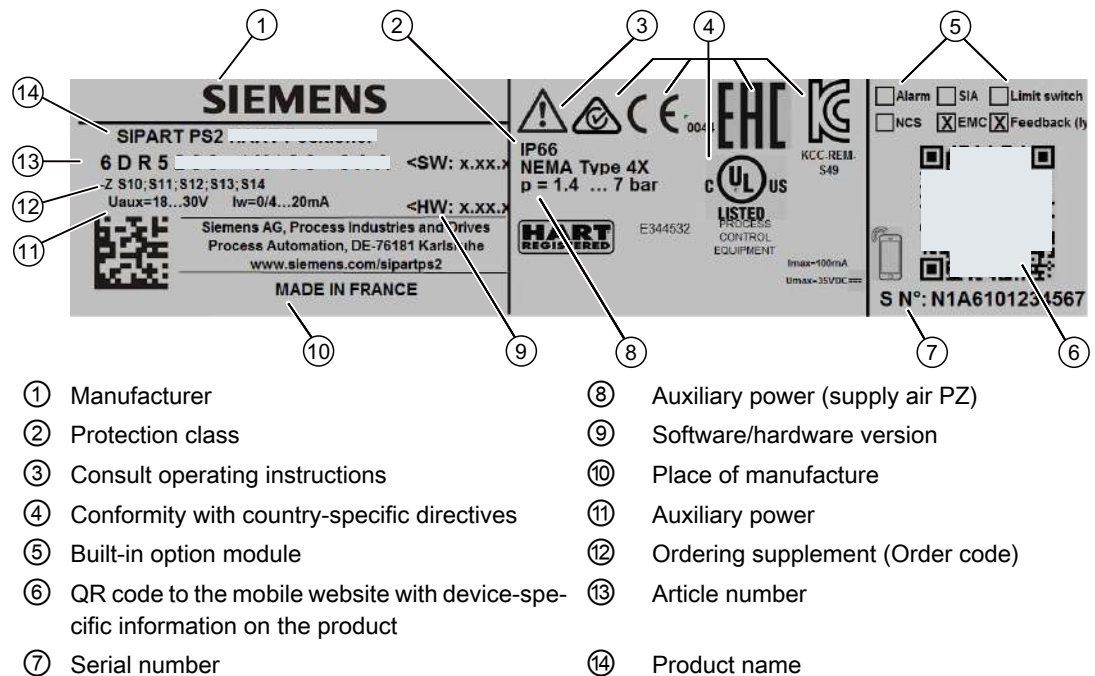

Figure 1-1 Nameplate layout, example

Layout of Ex nameplate

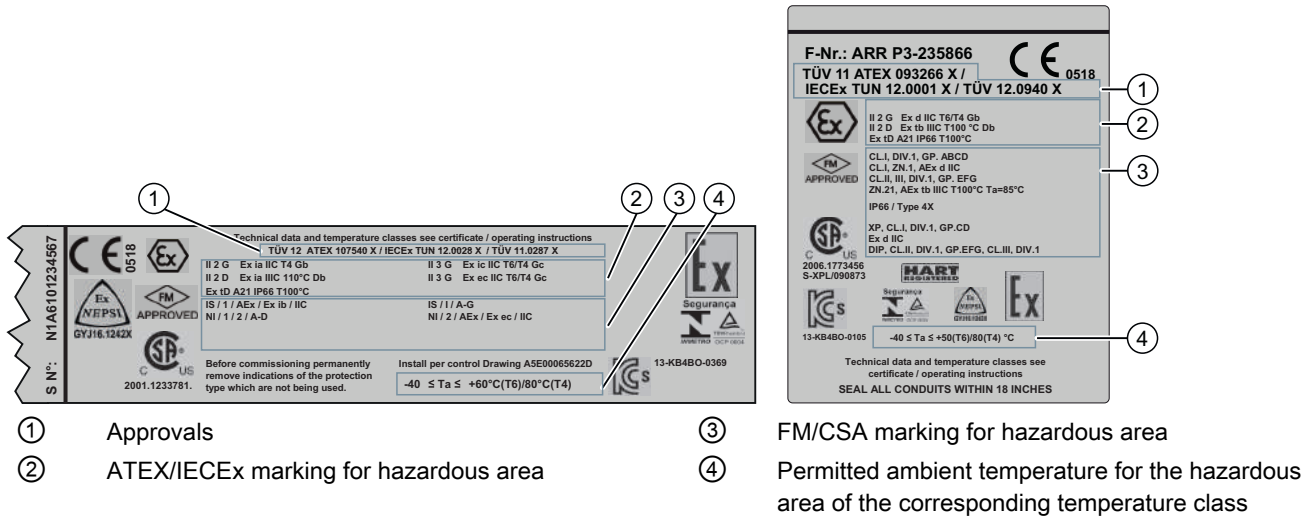

Figure 1-2 Ex nameplate layout, example

1.6 Security information

Siemens provides products and solutions with industrial security functions that support the secure operation of plants, systems, machines, and networks.

In order to protect plants, systems, machines and networks against cyber threats, it is necessary to implement – and continuously maintain – a holistic, state-of-the-art industrial security concept. Siemens’ products and solutions only form one element of such a concept.

Customer is responsible to prevent unauthorized access to its plants, systems, machines and networks. Systems, machines and components should only be connected to the enterprise network or the internet if and to the extent necessary and with appropriate security measures (e.g. use of firewalls and network segmentation) in place.

Additionally, Siemens’ guidance on appropriate security measures should be taken into account. For more information about industrial security, please visit:

<http://www.siemens.com/industrialsecurity>.

Siemens’ products and solutions undergo continuous development to make them more secure. Siemens strongly recommends to apply product updates as soon as available and to always use the latest product versions. Use of product versions that are no longer supported, and failure to apply latest updates may increase customer’s exposure to cyber threats.

To stay informed about product updates, subscribe to the Siemens Industrial Security RSS Feed under

<http://www.siemens.com/industrialsecurity>.

1.7 Transportation and storage

To guarantee sufficient protection during transport and storage, observe the following:

- Keep the original packaging for subsequent transportation.
- Devices/replacement parts should be returned in their original packaging.
- If the original packaging is no longer available, ensure that all shipments are properly packaged to provide sufficient protection during transport. Siemens cannot assume liability for any costs associated with transportation damages.

NOTICE
Insufficient protection during storage
The packaging only provides limited protection against moisture and infiltration.
<ul style="list-style-type: none">• Provide additional packaging as necessary.

Special conditions for storage and transportation of the device are listed in Technical data (Page 69).

1.8 Notes on warranty

The contents of this manual shall not become part of or modify any prior or existing agreement, commitment or legal relationship. The sales contract contains all obligations on the part of Siemens as well as the complete and solely applicable warranty conditions. Any statements regarding device versions described in the manual do not create new warranties or modify the existing warranty.

The content reflects the technical status at the time of publishing. Siemens reserves the right to make technical changes in the course of further development.

Safety instructions

2.1 Precondition for use

This device left the factory in good working condition. In order to maintain this status and to ensure safe operation of the device, observe these instructions and all the specifications relevant to safety.

Observe the information and symbols on the device. Do not remove any information or symbols from the device. Always keep the information and symbols in a completely legible state.

2.2 Warning symbols on the device

Symbol	Meaning
	Consult operating instructions

2.3 Laws and directives

Observe the safety rules, provisions and laws applicable in your country during connection, assembly and operation. These include, for example:

- National Electrical Code (NEC - NFPA 70) (USA)
- Canadian Electrical Code (CEC) (Canada)

Further provisions for hazardous area applications are for example:

- IEC 60079-14 (international)
- EN 60079-14 (EC)

2.4 Conformity with European directives

The CE marking on the device shows conformity with the regulations of the following European guidelines:

Electromagnetic compatibility EMC 2014/30/EU Directive of the European Parliament and of the Council on the harmonization of the laws of the Member States relating to electromagnetic compatibility.

Atmosphère explosible ATEX 2014/34/EU Directive of the European Parliament and of the Council on the harmonization of the laws of the Member States relating to equipment and protective systems intended for use in potentially explosive atmospheres.

The directives applied can be found in the EU declaration of conformity for the associated device.

2.5 Improper device modifications

WARNING

Improper device modifications

Risk to personnel, system and environment can result from modifications to the device, particularly in hazardous areas.

- Only carry out modifications that are described in the instructions for the device. Failure to observe this requirement cancels the manufacturer's warranty and the product approvals.

WARNING

Improper modification on positioner 6DR5...6

Danger of explosion. The pneumatic terminal plate on the SIPART PS2 positioner 6DR5..6 is a safety-related component of the flameproof enclosure.

- Never loosen the screws  of the pneumatic terminal plate.

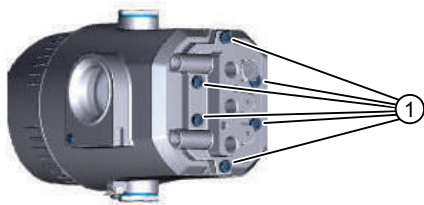



Figure 2-1 Screws of the pneumatic terminal plate on the positioner 6DR5..6

2.6 Use in areas subject to explosion hazard

Qualified personnel for hazardous area applications

Persons who install, connect, commission, operate, and service the device in a hazardous area must have the following specific qualifications:

- They are authorized, trained or instructed in operating and maintaining devices and systems according to the safety regulations for electrical circuits, high pressures, aggressive, and hazardous media.
- They are authorized, trained, or instructed in carrying out work on electrical circuits for hazardous systems.
- They are trained or instructed in maintenance and use of appropriate safety equipment according to the pertinent safety regulations.

 WARNING
Use in hazardous areas Risk of explosion. <ul style="list-style-type: none">• Only use equipment that is approved for use in the intended hazardous area and labelled accordingly.

See also

Technical data (Page 69)

 WARNING
Loss of safety of device with type of protection "Intrinsic safety Ex i" If the device has already been operated in non-intrinsically safe circuits or the electrical specifications have not been observed, the safety of the device is no longer ensured for use in hazardous areas. There is a risk of explosion. <ul style="list-style-type: none">• Connect the device with type of protection "Intrinsic safety" solely to an intrinsically safe circuit.• Observe the specifications for the electrical data on the certificate and/or in Technical data (Page 69).

2.6 Use in areas subject to explosion hazard

Installing/mounting

3.1 Basic safety instructions

 **WARNING**

High operating force with pneumatic actuators

Risk of injury when working on control valves due to the high operating force of the pneumatic actuator.

- Please observe the corresponding safety instructions for the pneumatic actuator in use.

 **WARNING**

Lever for position detection

Danger of crushing and shearing with mounting kits which use a lever for position detection. During commissioning and ongoing operation, severing or squeezing of limbs could occur as a result of the lever. Risk of injury when working on control valves due to the high operating force of the pneumatic actuator.

- Do not reach into the range of motion of the lever following mounting of the positioner and mounting kit.

 **WARNING**

Impermissible accessories and spare parts

Risk of explosion in areas subject to explosion hazard.

- Only use original accessories or original spare parts.
- Observe all relevant installation and safety instructions described in the instructions for the device or enclosed with the accessory or spare part.

 **WARNING**

It is possible to damage the cover gasket

If the cover gasket is not positioned correctly in the groove of the base plate, it could be damaged when the cover is mounted and screwed tight.

- Therefore make sure that the gasket is seated correctly.

 WARNING
Exceeded maximum permissible operating pressure
Risk of injury or poisoning.
The maximum permissible operating pressure depends on the device version, pressure limit and temperature rating. The device can be damaged if the operating pressure is exceeded. Hot, toxic and corrosive process media could be released.
Ensure that maximum permissible operating pressure of the device is not exceeded. Refer to the information on the nameplate and/or in Technical data (Page 69).

 CAUTION
Unsuitable compressed air
Device damage. As a general rule, the positioner must only be operated with dry and clean compressed air.
<ul style="list-style-type: none">• Use the customary water separators and filters. An additional dryer is required in extreme cases.• Use dryers, especially if you operate the positioner at low ambient temperatures.

 CAUTION
Please note the following before working on the control valve and when attaching the positioner
Danger of injury.
<ul style="list-style-type: none">• Prior to working on the control valve, you must move the control valve into a completely pressureless state. Proceed as follows:<ul style="list-style-type: none">– Depressurize the actuator chambers.– Switch off the supply air PZ.– Lock the valve in its position.• Make sure that the valve has reached the pressureless state.• If you interrupt the pneumatic auxiliary power to the positioner, the pressureless position may only be reached after a certain waiting time.• When mounting, observe the following sequence imperatively to avoid injuries or mechanical damage to the positioner/mounting kit:<ul style="list-style-type: none">– Mount the positioner mechanically.– Connect the electrical auxiliary power supply.– Connect the pneumatic auxiliary power supply.– Commission the positioner.

 WARNING
Mechanical impact energy
In order to ensure the degree of protection of the housing (IP66), protect the housing versions of the positioners listed here from mechanical impact energy:
<ul style="list-style-type: none">• 6DR5..3; not greater than 2 Joule• 6DR5..0; not greater than 1 Joule• 6DR5..1 with inspection window; not greater than 1 Joule

NOTICE
Torque with NPT screwed gland
Device damage. The maximum torque of the cable gland must not be exceeded.
<ul style="list-style-type: none">• To avoid damage to the device, the NPT adapter must be held in place while the NPT gland is screwed into the NPT adapter. Refer to the section "Technical specifications > Construction (Page 70)" for the torque value.

3.1.1 Proper mounting

NOTICE
Incorrect mounting
The device can be damaged, destroyed, or its functionality impaired through improper mounting.
<ul style="list-style-type: none">• Before installing ensure there is no visible damage to the device.• Make sure that process connectors are clean, and suitable gaskets and glands are used.• Mount the device using suitable tools. Refer to the information in Construction (Page 70) for installation torque requirements.

 CAUTION
Loss of type of protection
Damage to device if the enclosure is open or not properly closed. The type of protection specified on the nameplate or in Technical data (Page 69) is no longer guaranteed.
<ul style="list-style-type: none">• Make sure that the device is securely closed.

3.2 Mounting the linear actuator

For linear actuators, use the "linear actuator" mounting kit 6DR4004-8V or the integrated attachment.

You require different installation parts depending on the selected actuator type. The mounting kit is suitable for a stroke of 3 to 35 mm. For a larger stroke range, you require a separately ordered lever 6DR4004-8L. Refer to the detailed operating instructions for further information on mounting.

3.3 Mounting the part-turn actuator

You require an actuator-specific VDI/VDE 3845 mount to install the positioner on a part-turn actuator. You receive the mount and screws from the actuator manufacturer. Ensure that the mount has a sheet metal thickness of > 4 mm and reinforcements. You also need the mounting kit 6DR4004-8D or the stainless steel coupling TGX: 16300-1556. Refer to the detailed operating instructions for further information on mounting.

3.4 Using the positioner in a humid environment

Introduction

The positioner enclosure provides IP66 protection with an intended installation position. It can therefore be operated in a moist or wet environment in the mounting positions shown below. Do not use other mounting positions since it would then be possible for liquids, fluff, fibers or dusts to enter the device via the exhaust openings.

Favorable and unfavorable mounting positions

Avoid the unfavorable mounting positions:

- To prevent fluids seeping through during normal operation of the device, e.g. through exhaust air openings.
- Otherwise the display becomes poorly legible.

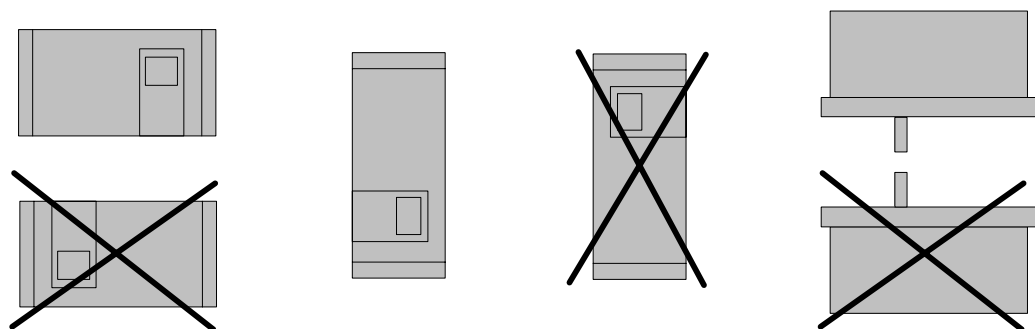

Figure 3-1 Favorable and unfavorable mounting positions

Additional measures to prevent liquids from seeping through

Take additional measures to prevent liquids from seeping through if the conditions force you to operate the positioner in an unfavorable mounting position.

Additional measures required to prevent liquids from seeping through depend on the selected mounting position. You may also require:

- Gland with sealing ring, e.g. FESTO: CK - 1 / 4-PK-6
- Approximately 20 to 30 cm plastic hose, e.g. FESTO: PUN - 8 x 1.25 SW
- Cable tie; the number and the length depend on the local conditions.

Procedure

1. Install the casing such that rain water or condensate running along the pipes can be drained before the terminal strip of the positioner.
2. Check the seals of electrical connections for perfect fitting.
3. Check the seal in the enclosure cover for damage and contaminations. Clean and/or replace if required.
4. Install the positioner such that the sintered bronze attenuator at the bottom side of the enclosure points downwards in the vertical mounting position. If this is not possible, replace the attenuator with a suitable gland with a plastic hose.

Procedure for installing the plastic hose on the gland

1. Unscrew the sintered bronze attenuator from the exhaust air opening at the bottom side of the enclosure.
2. Screw in the aforementioned gland into the exhaust air opening.
3. Install the aforementioned plastic hose into the gland and check whether it fits firmly.
4. Fasten the plastic hose with a cable tie onto the control valve such that the opening points downwards.
5. Ensure that the plastic hose does not have any kinks and the exhaust air flows out without any hindrance.

3.5 Positioners subjected to fast acceleration or strong vibration

The electropneumatic positioner has an gear latch for the friction clutch and for the transmission ratio selector.

Strong acceleration forces act on control valves that are subjected to heavy mechanical loads, e.g. breakaway valves, strongly shaking or vibrating valves, as well as in case of "vapor shocks". These forces may be much higher than the specified data. This may cause the friction clutch to move in extreme cases.

The positioner is equipped with an gear latch for the friction clutch to counter these extreme cases. The setting of the transmission ratio selector can also be locked.

3.5 Positioners subjected to fast acceleration or strong vibration

The locking procedure is illustrated and described below.

Note

Use of external NCS sensor / internal NCS module

If you use the accessory part "NCS sensor for contactless position measurement" or a built-in internal NCS module, the locking and fixing measures described in this section are **not** necessary.

Overview diagram

NOTICE
Wrong detection of the rotary or part-turn movement
A different setting of the transmission ratio selector and the gear latch results in a hysteresis in position detection. The hysteresis in position detection can result in unstable control behavior of the higher level control loop.
<ul style="list-style-type: none">• Make sure the transmission ratio selector ⑤ and the gear latch ① are set to the same value, either to 33° or to 90°.

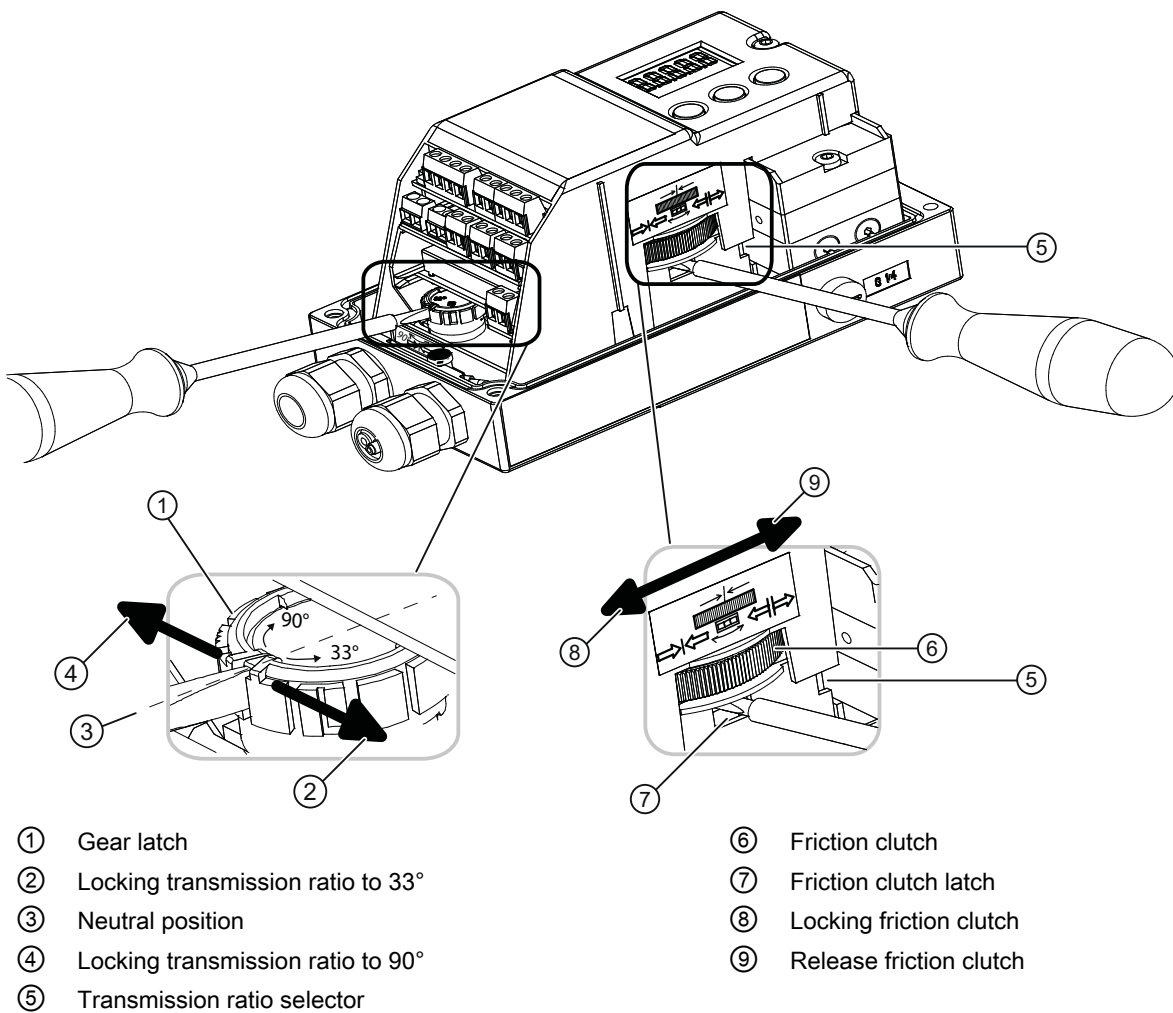

Figure 3-2 Locking friction clutch and transmission ratio

Requirements

- The positioner is mounted.
- You know whether the transmission ratio is to be set to 33° or 90°.
- The positioner has been commissioned successfully, i.e. initialization was completed with "FINISH".

Procedure

NOTICE

The following is applicable for the "flameproof enclosure" version:

- A friction clutch is provided on the outside of the positioner axis. Change the work area using this friction clutch.
- Do not open the flameproof enclosure of the positioner in explosion-prone atmospheres.

Fix the setting acquired by initialization as follows:

1. Make sure the gear latch ① is in neutral position ③. The neutral position is between 33° and 90°.
2. Make sure the transmission ratio selector ⑤ is in the correct position.
3. Fix the transmission ratio with the gear latch ①. Turn the gear latch ① with a standard approx. 4 mm wide screwdriver until the gear latch ① locks. Turning right locks the transmission ratio to 33° ②. Turning left locks the transmission ratio to 90° ④. The transmission ratio is locked.

Note

Changing the setting of the transmission ratio selector

The setting of the transmission ratio selector ⑤ can only be changed effectively if the gear latch ① is in the neutral position ③.

4. To fix the friction clutch ⑥ insert a standard approx. 4 mm wide screwdriver in the friction clutch gear latch ⑦.
5. Use the screwdriver to turn the friction clutch gear latch ⑦ counterclockwise until it engages. The friction clutch ⑥ is locked.

3.6 Installing option modules

A number of option modules are provided for the positioner. Different option modules are available depending on the version of the device. Only the available option modules are listed below.

For additional information and the corresponding safety notes to be observed when installing the option modules, refer to the detailed operating instructions for your respective device version.

Option modules in standard and intrinsically safe versions

The following option modules are available:

- Position feedback module
- Alarm module
- SIA module
- Mechanical limit switch module

- EMC filter module
- NCS sensor
- Internal NCS module

Option modules in "flameproof enclosure" version

The following option modules are available:

- Position feedback module
- Alarm module
- Internal NCS module

3.6.1 Internal NCS module

The internal NCS module is used for wear-free position detection and is an optional equipment version in the positioner. The internal NCS module is installed as an alternative to position feedback module at the same slot in the positioner.

Connecting

4.1 Basic safety instructions

 WARNING
<p>With intrinsically device version (Ex i)</p> <p>Risk of explosion in hazardous areas.</p> <p>For intrinsically safe device versions only the certified circuits may be connected as auxiliary power supply, control and signal circuits.</p> <ul style="list-style-type: none"> • Make sure that the power source of the used circuits is marked as intrinsically safe.

 WARNING
<p>Unsuitable cables, cable glands and/or plugs</p> <p>Risk of explosion in hazardous areas.</p> <ul style="list-style-type: none"> • Use only cable glands/plugs that comply with the requirements for the relevant type of protection. • Tighten the cable glands in accordance with the torques specified in Technical data (Page 69). • Close unused cable inlets for the electrical connections. • When replacing cable glands use only cable glands of the same type. • After installation check that the cables are seated firmly.

See also

Construction (Page 70)

NOTICE
<p>Condensation in the device</p> <p>Damage to device through formation of condensation if the temperature difference between transportation or storage and the mounting location exceeds 20 °C (36 °F).</p> <ul style="list-style-type: none"> • Before taking the device into operation let the device adapt for several hours in the new environment.

NOTICE
Ambient temperature too high
Damage to cable sheath.
<ul style="list-style-type: none">• At an ambient temperature $\geq 60\text{ °C}$ (140 °F), use heat-resistant cables suitable for an ambient temperature at least 20 °C (36 °F) higher.

 WARNING
Improper power supply
Risk of explosion in hazardous areas as result of incorrect power supply, e.g. using direct current instead of alternating current.
<ul style="list-style-type: none">• Connect the device in accordance with the specified power supply and signal circuits. The relevant specifications can be found in the certificates, in Technical data (Page 69) or on the nameplate.

 WARNING
Unsafe extra-low voltage
Risk of explosion in hazardous areas due to voltage flashover.
<ul style="list-style-type: none">• Connect the device to an extra-low voltage with safe isolation (SELV).

 WARNING
Lack of equipotential bonding
Risk of explosion through compensating currents or ignition currents through lack of equipotential bonding.
<ul style="list-style-type: none">• Ensure that the device is potentially equalized.
Exception: It may be permissible to omit connection of the equipotential bonding for devices with type of protection "Intrinsic safety Ex i".

 WARNING
Unprotected cable ends
Risk of explosion through unprotected cable ends in hazardous areas.
<ul style="list-style-type: none">• Protect unused cable ends in accordance with IEC/EN 60079-14.

⚠ WARNING**Improper laying of shielded cables**

Risk of explosion through compensating currents between hazardous area and the non-hazardous area.

- Shielded cables that cross into hazardous areas should be grounded only at one end.
- If grounding is required at both ends, use an equipotential bonding conductor.

⚠ WARNING**Connecting device in energized state**

Risk of explosion in hazardous areas.

- Connect devices in hazardous areas only in a de-energized state.

Exceptions:

- Devices having the type of protection "Intrinsic safety Ex i" may also be connected in energized state in hazardous areas.
- Exceptions for type of protection "Increased safety ec" (Zone 2) are regulated in the relevant certificate.

⚠ WARNING**Incorrect selection of type of protection**

Risk of explosion in areas subject to explosion hazard.

This device is approved for several types of protection.

1. Decide in favor of one type of protection.
2. Connect the device in accordance with the selected type of protection.
3. In order to avoid incorrect use at a later point, make the types of protection that are not used permanently unrecognizable on the nameplate.

NOTICE**Standard cable gland/torque**

Device damage.

- Owing the reasons pertaining to tightness (IP enclosure rating) and the required tensile strength, only use the cables having a diameter ≥ 8 mm for standard M20x1.5 cable gland, or use a suitable seal insert in case of smaller diameters.
- In the NPT version, the positioner is delivered with a coupling. When inserting a counter piece in the coupling, ensure that the maximum permissible torque of 10 Nm is not exceeded.

 **CAUTION**

Maximum AC/DC switching voltage with UL approval E344532

The mechanical limit switch module 6DR4004-**6K** is approved for use for positioners with UL approval. The maximum supply voltage in this case is 30 V AC/DC.

The mechanical limit switch module 6DR4004-**8K** is not approved for use for positioners with UL approval.

If this information is ignored, the UL approval for the mechanical limit switch module for the positioner becomes invalid.

Two-wire mode

NOTICE

Connection of voltage source to current input

Device damage if a voltage source is connected to the current input I_w (terminals 6 and 7).

- Never connect the current input I_w to a voltage source, otherwise the positioner may be destroyed.
- Always use a voltage source with a maximum output current of $I = 20$ mA.

Note

Improvement of interference immunity

- Lay signal cables separate from cables with voltages > 60 V.
 - Use cables with twisted wires.
 - Keep device and cables at a distance from strong electromagnetic fields.
 - Take account of the conditions for communication specified in the Technical data (Page 69).
 - HART: Use shielded cables to guarantee the full specification according to HART.
-

4.1.1 Additional safety notes for PA and FF

If the bus shield is fully effective, the interference immunity and the interference emission conform to the specifications. The following measures ensure that the bus shield is fully effective:

- The shields have been connected to the metallic connections of the positioner.
- The shields have been laid up to the terminal boxes, the distributor and the transceiver.

Note

Dissipation of glitch impulses/equipotential bonding

In order to dissipate glitch impulses, the positioner must be connected to an equipotential bonding cable (earth potential) using a low resistance. The positioner in the Makrolon enclosure is therefore equipped with an additional cable. Connect this cable to the shield of the bus cable and the equipotential bonding cable using a cable clamp.

Devices in the stainless steel or aluminum enclosure have a corresponding terminal on the outer side of the enclosure. This terminal must also be connected to the equipotential bonding cable.

For applications in hazardous areas, ensure an adequately suitable equipotential bonding between the hazardous and non-hazardous areas.

The positioner is equipped with an additional input (terminal 81 [+] and terminal 82 [-]) to approach the safety position. After activating this function, this input must be continuously supplied with +24 V in order to retain the normal control function.

If the 24-V signal is interrupted, the safety position is set as described in chapter "Pneumatic connection (Page 44)".

Communication with the master is still possible. The "Jumper" on the basic electronics is used to activate this function. It can be accessed after removing the module cover, and must be switched from the right position (delivery state) to the left position.

4.2 Electrical connection

4.2.1 SIPART PS2 with and without HART

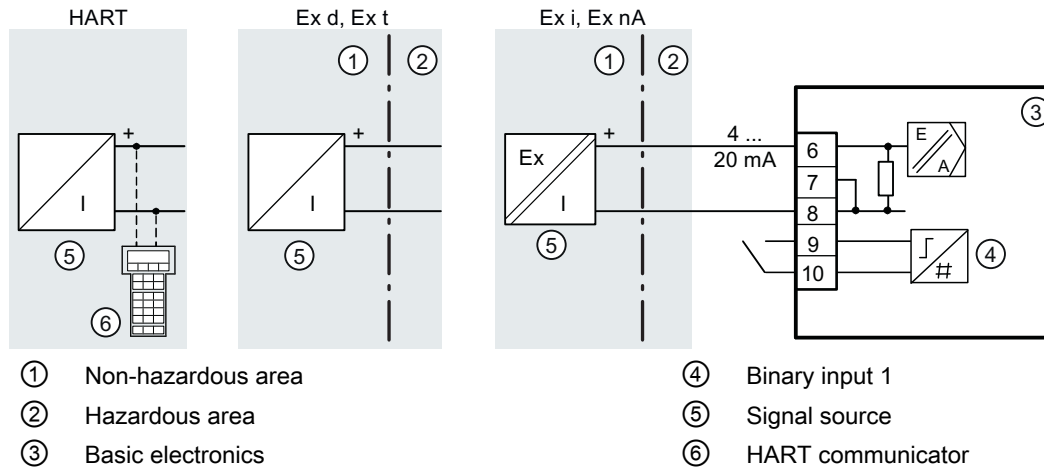

Figure 4-1 Device version 2-wire

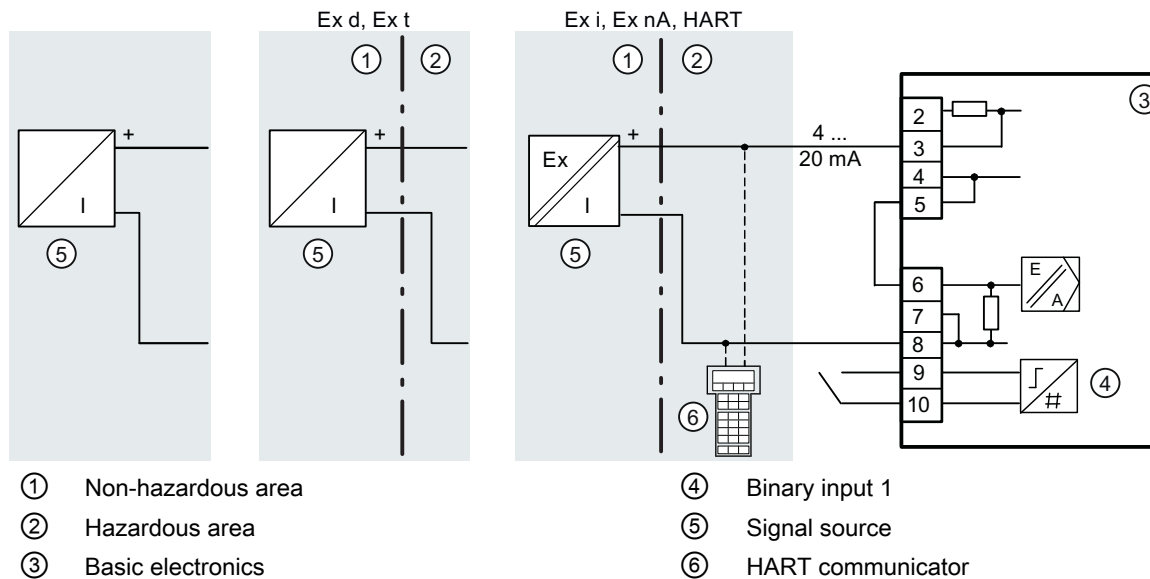

Figure 4-2 Device version 2/3/4-wire, with connection type 2-wire

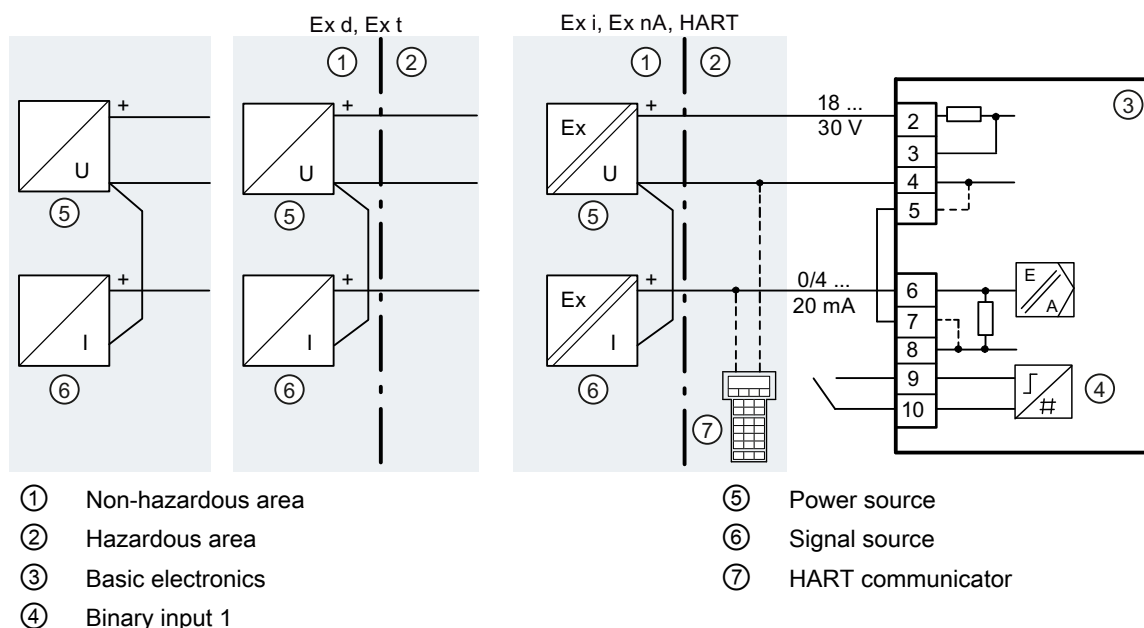

Figure 4-3 Device version 2-/3-/4-wire, with wiring type 3-wire

4.2.1.1 Basic electronics, 2/3/4-wire, with connection type 4-wire, connection diagram (with and without HART)

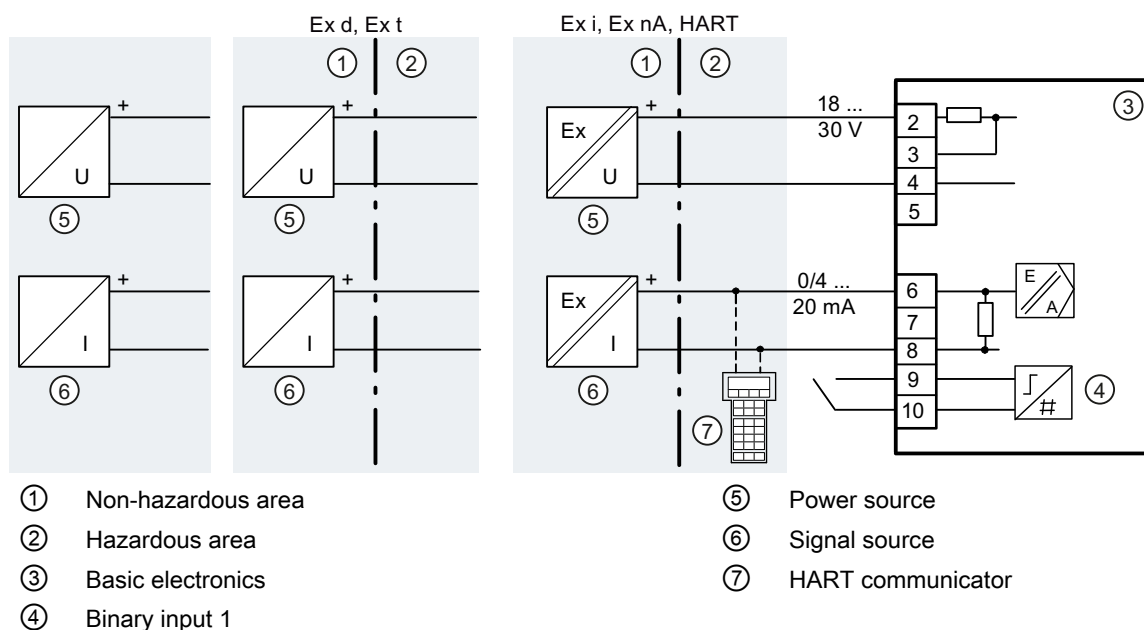

Figure 4-4 Device version 2-/3-/4-wire, with wiring type 4-wire

4.2.2 SIPART PS2 with PROFIBUS PA

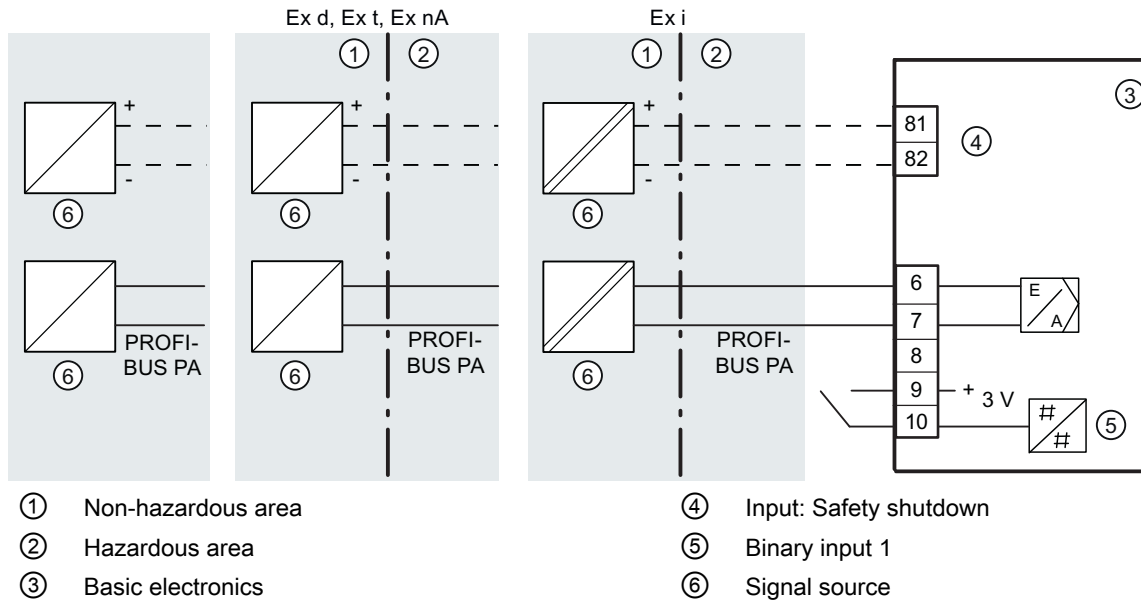

Figure 4-5 Device version with PROFIBUS PA

4.2.3 SIPART PS2 with FOUNDATION Fieldbus

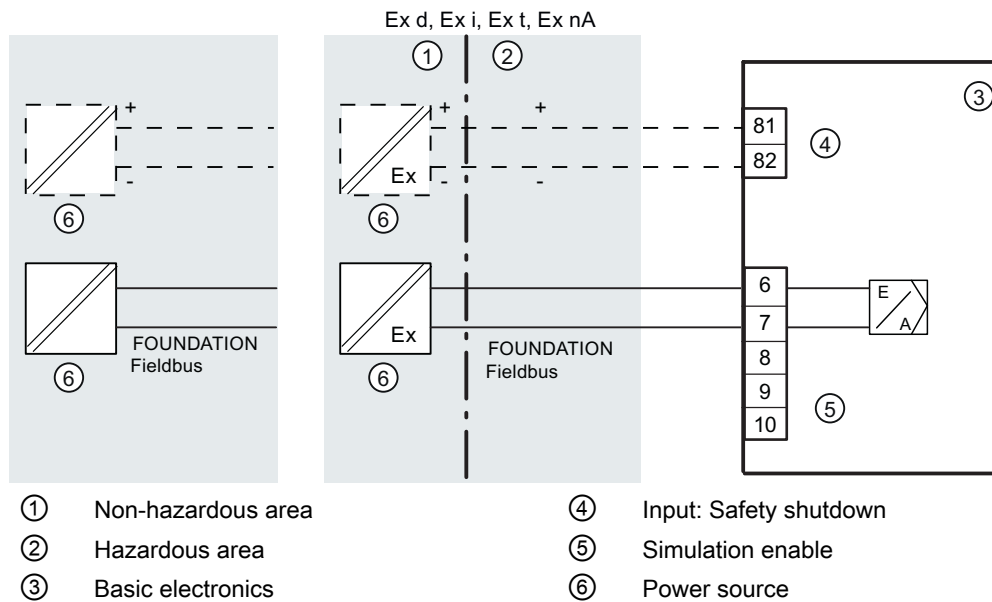

Figure 4-6 Device version with FOUNDATION Fieldbus

4.2.4 Split range

For further information about "Split-range" operation, refer to the detailed operating instructions for your respective device version.

4.2.5 Option modules

4.2.5.1 Alarm modules 6DR4004-6A and -8A

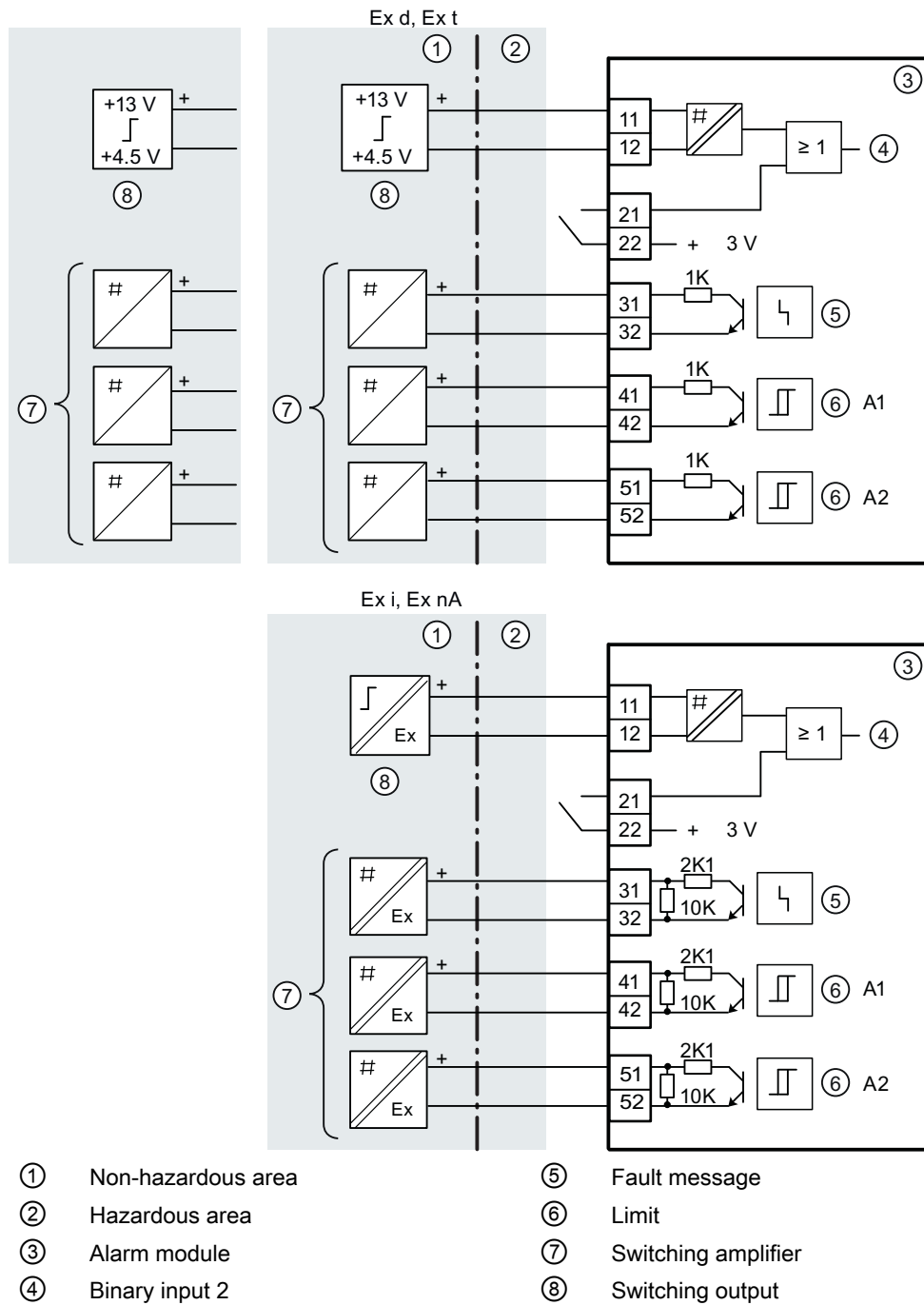

Figure 4-7 Alarm module

4.2.5.2 Position feedback modules 6DR4004-6J and -8J

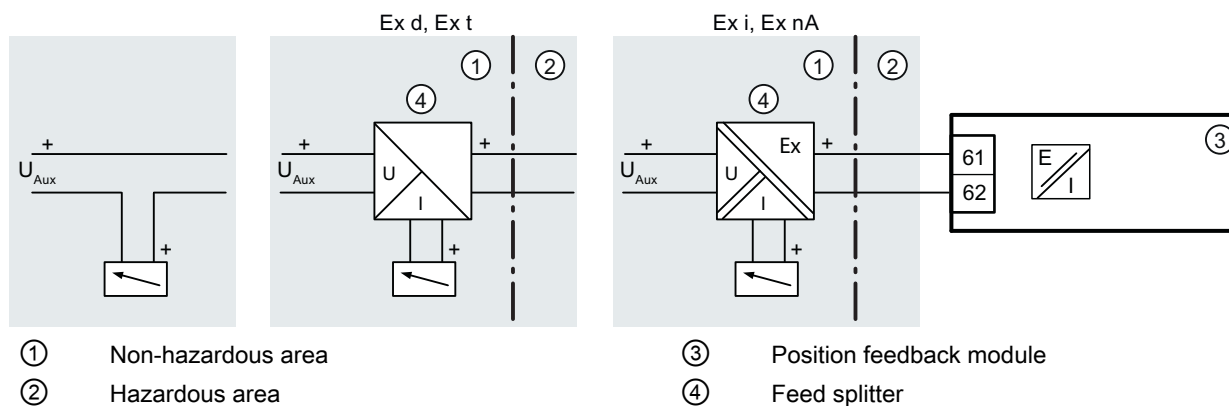

Figure 4-8 Position feedback module

4.2.5.3 SIA modules 6DR4004-6G and -8G

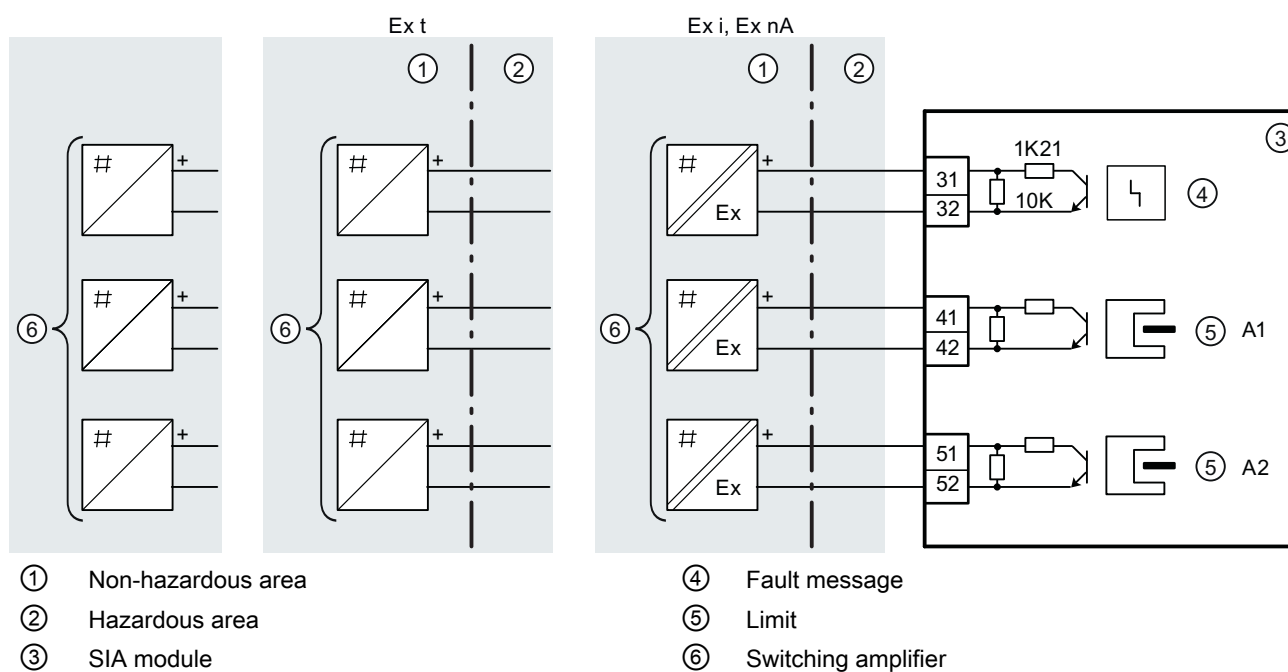

Figure 4-9 SIA module

4.2.5.4 Mechanical limit switch modules 6DR4004-6K and -8K

⚠ DANGER

Supply with hazardous voltage

When you supply the non-intrinsically safe version of the module with hazardous voltage, you must read the following safety rules before starting work on the device:

1. Isolate the device from power. Use a circuit breaker positioned near the device to do this.
2. Make sure that the device cannot be switched back on inadvertently.
3. Make sure the device is truly isolated from power.

⚠ CAUTION

Maximum AC/DC switching voltage with UL approval E344532

The mechanical limit switch module 6DR4004-6K is approved for use for positioners with UL approval. The maximum supply voltage in this case is 30 V AC/DC.

The mechanical limit switch module 6DR4004-8K is not approved for use for positioners with UL approval.

If this information is ignored, the UL approval for the mechanical limit switch module for the positioner becomes invalid.

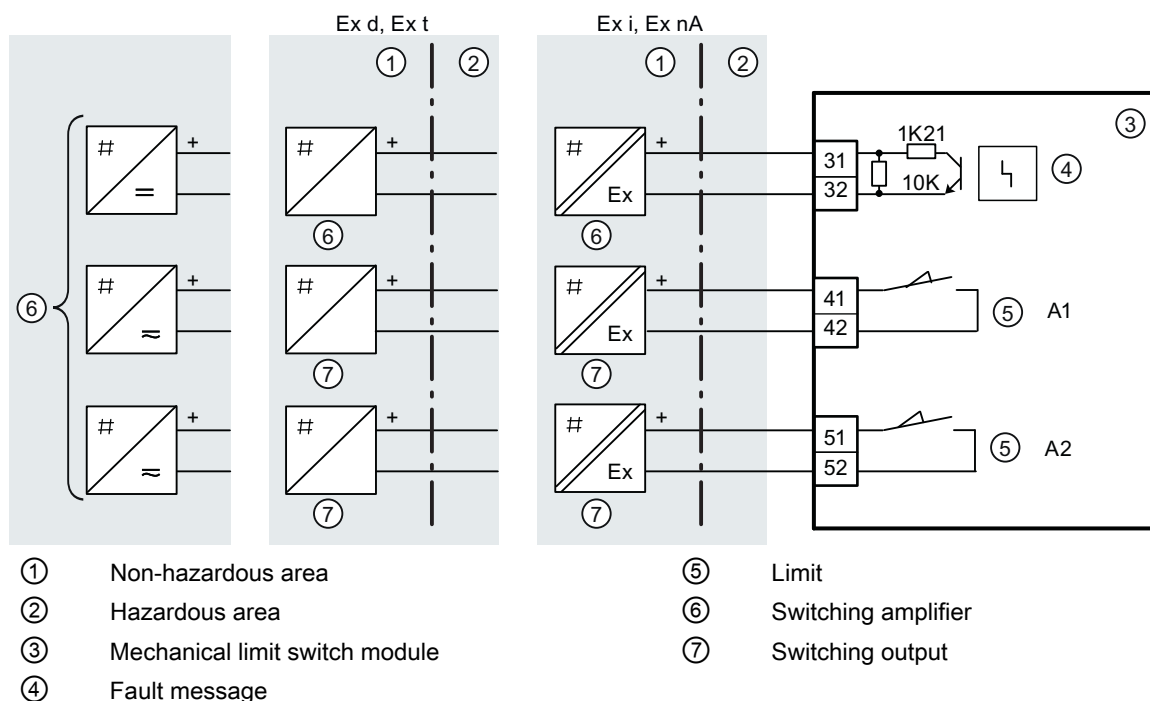

Figure 4-10 Mechanical limit switch module

Procedure

1. Loosen the screw ① on the transparent cover ②.
2. Pull the transparent cover ② up to the front end stop.
3. Tighten every cable in the corresponding terminal.
4. Slide the transparent cover ② up to the end stop of the basic electronics.
5. Tighten the screw ① of the transparent cover ②.
6. Connect the cables of each switch to the lug of the printed circuit board in pairs. Use the provided cable ties ③ for this purpose.

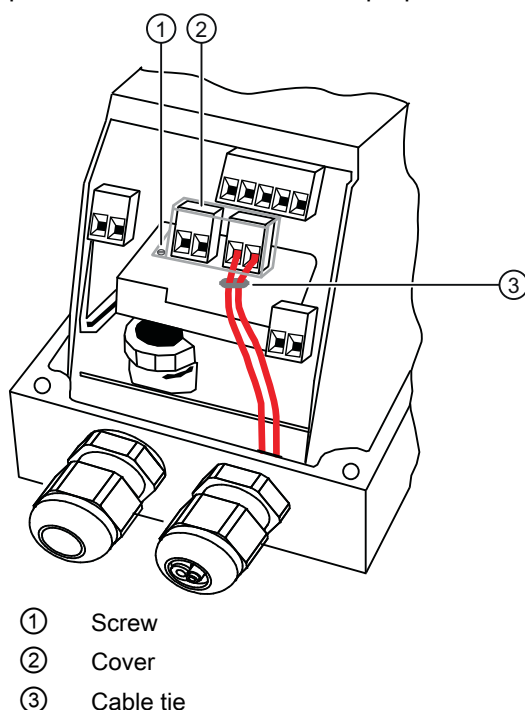

Figure 4-11 Connecting the cables

4.2.6 Option device version M12 connector

This section describes which terminal of the devices and option modules listed below is connected with the respective pole of the M12 connector.

Note

Technical specifications

Observe the specifications for the electrical data in the certificate and/or in section "Technical data (Page 69)".

View of the mating side pole pattern

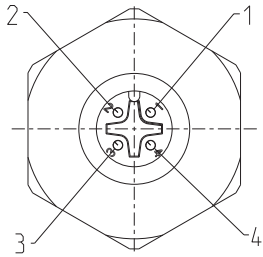

Pole designation	Wire color of M12 connector
1	Brown
4	Black
3	Blue
2	White

4.2.6.1 M12 connector in basic device SIPART PS2 with and without HART

You have a positioner 6DR50..-0.R.. or 6DR50..-0.S.. In this version of the positioner, the current input I_w 4 to 20 mA of the basic electronics is connected via the M12 connector.

Table 4-1 Assignment diagram

Current input terminal	Pole designation
6 (+)	1 - Brown
Shield support of housing	4 - Black
7 and 8 (-)	3 - Blue

4.2.6.2 M12 connector in basic device SIPART PS2 with PROFIBUS PA

You have a positioner 6DR55..-0.R.. or 6DR55..-0.S.. In this case the M12 connector is connected to the bus circuit of the basic electronics.

Table 4-2 Assignment diagram

Bus circuit terminal	Pole designation
7	1 - Brown
Shield support of housing	4 - Black
6	3 - Blue

4.2.6.3 M12 connector in basic device SIPART PS2 with FOUNDATION Fieldbus

You have a positioner 6DR56..-0.R.. or 6DR56..-0.S.. In this case the M12 connector is connected to the bus circuit of the basic electronics.

Table 4-3 Assignment diagram

Bus circuit terminal	Pole designation
7	1 - Brown
Shield support of housing	4 - Black
6	3 - Blue

4.2.6.4 M12 connector for connection of the outputs of the alarm module 6DR4004-6A / -8A (-Z D55)

You have a positioner with order suffix -Z order code D55. In this version of the positioner, the M12 connector is used to electrically connect the current output of the position feedback module.

Table 4-4 Assignment diagram

Alarm output terminal	Pole designation
41 (+)	1 - Brown
52 (-)	4 - Black
42 (-)	3 - Blue
51 (+)	2 - White

4.2.6.5 M12 connector for connecting the outputs of the position feedback module 6DR4004-6J / 8J (-Z D53)

You have a positioner with order suffix -Z order code D53. In this version of the positioner, the M12 connector is used to electrically connect the current output of the position feedback module.

Table 4-5 Assignment diagram

Current output terminal	Pole designation
61 (+)	1 - Brown
Shield support of housing	4 - Black
62 (-)	3 - Blue

4.2.6.6 M12 connector for connecting the external position detection system (-Z D54)

You have a positioner with order suffix -Z order code D54. In this version of the positioner, the M12 connector is used to electrically connect the fitted EMC filter module (C73451-A430-D23). Connect the external position detection system using the M12 connector.

Table 4-6 Assignment diagram

Terminal	Pole designation
POS (X1/2)	3 - Blue
VCC (X1/4)	1 - Brown
GND (X1/1)	4 - Black
VREF (X1/3)	2 - White

4.2.6.7 M12 connector for connecting the outputs of the SIA module 6DR4004-6G /-8G (-Z D56)

You have a positioner with order suffix -Z order code D56. In this version of the positioner, the M12 connector is used to electrically connect the outputs of the SIA module.

Table 4-7 Assignment diagram

Alarm output terminal	Pole designation
41 (+)	1 - Brown
52 (-)	4 - Black
42 (-)	3 - Blue
51 (+)	2 - White

4.3 Pneumatic connection

<p> WARNING</p> <p>Pneumatic auxiliary power</p> <p>Owing to safety reasons, the pneumatic auxiliary power supply must be fed after installation only if the positioner is switched to the "P-manual mode" when an electrical signal is available, refer to the as-delivered condition.</p>
--

Note

Specifications regarding air quality

Observe the specifications regarding the air quality, see section "Technical specifications > Pneumatic data (Page 70)".

- If required, connect the pressure gauge block for supply air and actuating pressure.
- Connection via female thread G¼ or ¼" NPT:
 - Y1: actuating pressure 1 for single and double-acting actuators
 - Y2: actuating pressure 2 for double-acting actuators
 - Exhaust air outlet with a sound absorber. Remove the sound absorber if required.

- For double-acting actuators, connect actuating pressure Y1 or Y2 depending on the desired safety setting.
- Safety position in case of electrical auxiliary power supply failure:
 - Positioner with single-acting pneumatic system: Y1 depressurized
 - Positioner with double-acting pneumatic system: Y1 pressurized (maximum actuating pressure), Y2 depressurized
 - Positioner with Fail in Place pneumatic system: Hold Y1 and Y2 (current actuating pressure)

Note**Leakage**

Besides continuous air consumption, a leakage can cause the positioner to try to compensate the position deviation. This will result in premature wear in the entire control device.

- After installing the pneumatic connections, check the tightness of the entire control valve.

4.3.1 Pneumatic connection for 6DR5..0/1/2/3

Structure

The pneumatic connections are provided on the right side of the positioner.

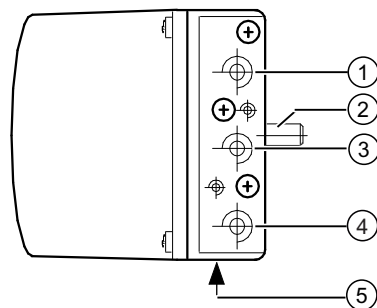

- ① Actuating pressure Y1 for single and double-acting actuators
- ② Positioner shaft
- ③ Supply air PZ
- ④ Actuating pressure Y2 for double-acting actuators
- ⑤ Exhaust air outlet with a sound absorber

Figure 4-12 Pneumatic connection on the standard controller

4.3.2 Pneumatic connection for 6DR5..5 and 6DR5..6

Structure

The pneumatic connections are provided on the right side of the positioner.

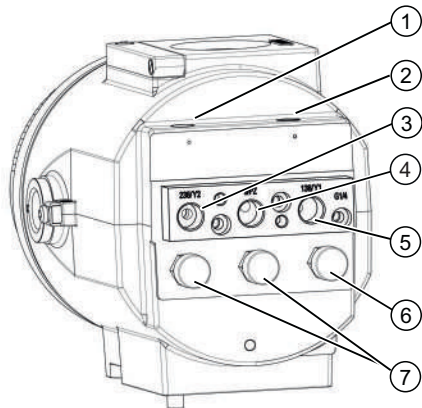

- | | |
|----------------------------|------------------------------|
| ① Restrictor Y2 *) | ⑤ Actuating pressure Y1 |
| ② Restrictor Y1 | ⑥ Exhaust air outlet |
| ③ Actuating pressure Y2 *) | ⑦ Enclosure ventilation (2x) |
| ④ Supply air PZ | |
- *) for double-acting actuators

Figure 4-13 Pneumatic connection in the flameproof enclosure

4.4 Restrictors

- Reduce the air output to achieve travel times of $T > 1.5$ s for small actuators. Use restrictors Y1 ① and Y2 ② for this purpose.
- When turned clockwise, they reduce the air output and finally shut it off.

- In order to set the restrictors, we recommend closing them and then opening slowly.
- In case of double-acting valves, ensure that both restrictors have approximately the same setting.

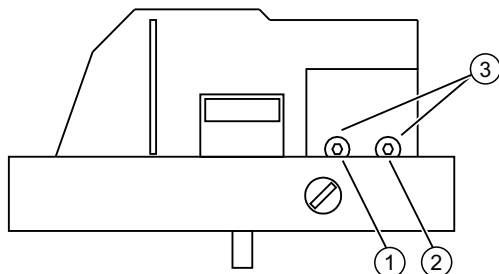

- ① Restrictor Y1
- ② Restrictor Y2, only in the version for double-acting actuators *)
- ③ Hexagon socket-head screw 2.5 mm

Figure 4-14 Restrictors

*) Restrictor Y2 ② is not active for single-acting Fail in Place F01

Commissioning

5.1 Basic safety instructions

 WARNING
Improper commissioning in hazardous areas Device failure or risk of explosion in hazardous areas. <ul style="list-style-type: none">• Do not commission the device until it has been mounted completely and connected in accordance with the information in Technical data (Page 69).• Before commissioning take the effect on other devices in the system into account.

 WARNING
Loss of explosion protection Risk of explosion in hazardous areas if the device is open or not properly closed. <ul style="list-style-type: none">• Close the device as described in Installing/mounting (Page 19).

 WARNING
Opening device in energized state Risk of explosion in areas subject to explosion hazard. <ul style="list-style-type: none">• Only open the device in a de-energized state.• Check prior to commissioning that the cover, cover locks, and cable inlets are assembled in accordance with the directives. Exception: Devices having the type of protection "Intrinsic safety Ex i" may also be opened in energized state in hazardous areas.

 WARNING
Water in compressed air line
Device damage and possibly loss of type of protection. The factory setting for the purging air selector is "IN". In the "IN" position, water from the compressed air line may enter the device from the pneumatics during initial commissioning.
<ul style="list-style-type: none">• Before commissioning, make sure that no water is present in the compressed air line.
If you cannot be sure that there is no water in the compressed air line:
<ul style="list-style-type: none">• Set the purging air selector to "OUT". In this way, you prevent water from the compressed air line from penetrating the device.• Only set the purging air selector to "IN" again when all water has been discharged from the compressed air line.

 CAUTION
Loss of type of protection
Damage to device if the enclosure is open or not properly closed. The type of protection specified on the nameplate or in Technical data (Page 69) is no longer guaranteed.
<ul style="list-style-type: none">• Make sure that the device is securely closed.

 WARNING
Commissioning and operation with pending error
If an error message appears, correct operation in the process is no longer guaranteed.
<ul style="list-style-type: none">• Check the gravity of the error.• Correct the error.• If the error still exists:<ul style="list-style-type: none">– Take the device out of operation.– Prevent renewed commissioning.

5.1.1 Safety notes for operation with natural gas

When operating the positioner with natural gas, you must follow and adhere to the following safety notes:

 WARNING
Operation with natural gas
<ol style="list-style-type: none">1. Only positioners and option modules which are connected to power supplies with type of protection "Intrinsic safety, protection level [ia]" may be operated with natural gas.2. Do not operate the positioner with natural gas in closed spaces.3. Natural gas is continuously blown off, depending on the model. Special care must therefore be taken during maintenance activities near the positioner. Always ensure that the immediate surroundings of the positioner are adequately ventilated. The maximum values for ventilation are listed in section "Natural gas as actuator medium (Page 75)".4. The mechanical limit switch module must not be used when operating the positioner with natural gas.5. Depressurize the devices operated with natural gas adequately during maintenance activities. Open the cover in an explosion-free atmosphere and depressurize the device for at least two minutes.

Note**Quality of natural gas**

Only use natural gas which is clean, dry and free from additives.

5.2 Overview

Note

- During the initialization process, the operating pressure must be at least one bar more than that required to close or open the valve. However, the operating pressure should not be greater than the maximum permissible operating pressure for the actuator.
-

General information about commissioning

1. After installing the positioner on a pneumatic actuator, you must supply electric and pneumatic auxiliary power to it.
2. The positioner is in the "P manual mode" before initialization. At the same time, "NOINI" blinks in the lower line of the display.

3. Position feedback: You can adjust the range of position detection using the friction clutch if necessary.
4. Adjust the positioner as per the respective actuator with the help of the initialization process and by setting the parameters. If required, use the "PRST" parameter to cancel the adjustment of the positioner on the actuator. The positioner is again in the "P manual mode" after this process.

Types of initialization

You can initialize the positioner as follows:

- Automatic initialization:
during automatic initialization, the positioner determines the following one after the other:
 - The direction of action
 - The actuator travel and angle of rotation
 - The travel time of the actuator

The positioner also adjusts the control parameters as per the dynamic response of the actuator.

- Manual initialization:
the actuator travel and the angle of rotation of the actuator are set manually. The remaining parameters are automatically determined. This function is useful for valves which are lined, for example, with PTFE.
- Copying the initialization data when replacing a positioner:
the initialization data of a positioner can be read and copied into another positioner. A defective device can thus be replaced without interrupting an ongoing process through initialization.

You have to define a few parameters for the positioner before initialization. Owing to the preset values, you cannot adjust further parameters for initialization.

You can use a suitably configured and activated binary input to protect the configured settings against accidental adjustment.

5.3 Sequence of automatic initialization

See detailed operating instructions for information on sequence of automatic initialization.

5.4 Parameter

5.4.1 Overview of initialization parameters 1 to 5

Introduction

Parameters 1 to 5 are the same for all versions of the positioner. These parameters are used to adjust the positioner to the actuator. Normally, setting these parameters is sufficient to be able to operate the positioner on an actuator.

If you want to get to know all details of the positioner, gradually try out the effects of the remaining parameters by systematic testing.

Note

Factory-set parameter values are printed in bold in the following table.

Overview

Parameter	Function	Parameter values		Unit
1.YFCT	Type of actuator	Normal	Inverted	
	Part-turn actuator	turn	-turn	
	Linear actuator	WAY	-WAY	
	Linear actuator - carrier pin on actuator spindle	FWAY	-FWAY	
	Linear actuator - external linear potentiometer (e.g. with cylinder drives)	LWAY	-LWAY	
	Part-turn actuator with NCS/iNCS	ncSt	-ncSt	
	Linear actuator with NCS	ncSL	-ncSL	
	Linear actuator with NCS/iNCS and lever	ncSLL	-ncLL	
2.YAGL	Rated angle of rotation of positioner shaft ¹⁾			Degrees
	33°			
	90°			
3.YWAY ²⁾	Range of stroke (optional setting) ³⁾			mm
	OFF			
	5 10 15 20 (Short lever 33°, range of stroke 5 to 20 mm)			
	25 30 35 (Short lever 90°, range of stroke 25 to 35 mm)			
40 50 60 70 90 110 130 (Long lever 90°, range of stroke 40 to 130 mm)				
4.INITA	Initialization (automatic)	NOINI no / ###.# Strt		
5.INITM	Initialization (manual)	NOINI no / ###.# Strt		

1)	Set the transmission ratio selector accordingly.
2)	Parameter only appears with "WAY", "-WAY", "ncSLL", and "-ncLL"
3)	If used, the value on the actuator must correspond to the set range of stroke on the lever arm. Carrier must be set to the value of the actuator travel or, if this value is not scaled, to the next larger scale value.

5.5 Purge air switching

When the enclosure is open, the purge air switch above the pneumatic terminal strip on the pneumatic block can be accessed.

- In the IN position, the enclosure is flushed from inside with a small volume of clean and dry instrument air.
- In the OUT position, the purge air is directly directed towards outside.

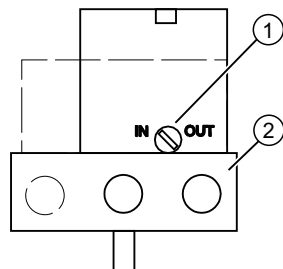

- ① Purging air selector
- ② Pneumatic connections Y1, PZ and Y2

Figure 5-1 Purge air switch on the pneumatic block; view of the positioner on the pneumatic connection side when the cover is open

The factory setting is the "IN" position.

5.6 Commissioning linear actuators

5.6.1 Preparing linear actuators for commissioning

Requirement

You have already installed the positioner using the suitable mounting kit.

Setting the transmission ratio selector

Commissioning

The setting of the transmission ratio selector is extremely important to commission the positioner.

Stroke [mm]	Position of the transmission ratio selector
5 ... 20	33°
25 ... 35	90°
40 ... 130	90°

Connecting the positioner

1. Connect a suitable current or voltage source. The positioner is now in the "P manual mode". The current potentiometer voltage (P) in percent is shown in the upper line of the display, e.g.: "P37.5", and "NOINI" flashes in the bottom line:



2. Connect the actuator and the positioner to the pneumatic lines.
3. Supply the pneumatic auxiliary power to the positioner.

Setting the actuator

1. Check whether the mechanical unit can be moved freely in the entire travel range. Move the actuator to the respective end position for this purpose using the \triangle or ∇ button.
End position
2. Now move the actuator to the horizontal position of the lever.
3. A value between "P48.0" and "P52.0" is shown on the display.
4. If a value beyond this range is shown on the display, you must move the friction clutch. Move the friction clutch until a value between "P48.0" and "P52.0" is reached. The closer this value is to "P50.0", the more accurately the positioner determines the stroke travel.
The following applies to the flameproof enclosure version:
The inner friction clutch is fixed. Therefore, only move the outer friction clutch. This also applies when using an internal NCS module.
The following applies to device versions without flameproof enclosure with internal NCS module 6DR4004-5L.:
The inner friction clutch has no function. This means you should only adjust the adjustment wheel of the magnet clamp. Requirement: Parameter '1.YFCT' is set.

5.6.2 Automatic initialization of linear actuators

Requirements

The following conditions must be fulfilled before activating the automatic initialization:

1. The actuator spindle can be moved completely.
2. The actuator spindle is at a central position after moving.

Initializing the linear actuator automatically

Note

Interrupting initialization

An ongoing initialization can be interrupted at any time. To do this, press . The settings configured until then are retained.

All parameters are reset to factory settings only if you have explicitly activated the preset settings in the "PRST" parameter.



1. Switch to the "Configuration" mode. To do this, keep the  button pressed for at least 5 seconds. The display shows the following:

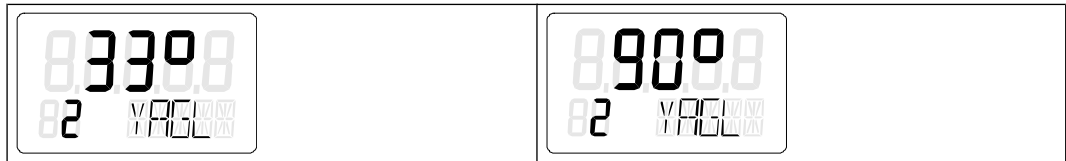

2. Call the "2.YAGL" parameter. To do this, press . The following is shown on the display depending on the setting:





3. Check whether the value displayed in the "2.YAGL" parameter matches the setting of the transmission ratio selector. If required, change the setting of the transmission ratio selector to 33° or 90°.

4. Set the "3.YWAY" parameter to determine the total stroke in mm. The setting of parameter 3 is optional. The display shows the determined total stroke only at the end of the initialization phase.
 - Press the  button if you do not require any information about the total stroke in mm. You are then directed to parameter 4.
 - Call the "3.YWAY" parameter. To do this, press . The display shows the following:

**Note****Set the "3.YWAY" parameter**

Proceed as follows to set parameter 3:

1. On the scale of the lever, read the value marked by the carrier pin.
2. Set the parameter with the buttons  and  to the read value.

5. Call the "4.INITA" parameter. To do this, briefly press the  button. The display shows the following:



6. Start the initialization process. To do this, keep the  button pressed for at least 5 seconds until the display shows the following:



The positioner runs through five initialization steps during the automatic initialization process. Displays for the initialization steps from "RUN 1" to "RUN 5" are shown in the lower line on the display. The initialization process depends on the actuator used, and takes up to 15 minutes.

7. The following display indicates that the automatic initialization is complete:



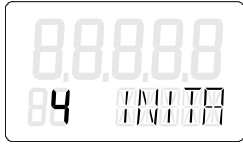

Aborting the automatic initialization process

1. Press the  button. The display shows the following:



The positioner is in the "Configuration" mode.

2. Exit the "Configuration" mode. To do this, keep the  button pressed for at least 5 seconds. The software status is displayed. After releasing the  button, the positioner is in "P manual mode". The positioner is not initialized.

5.6.3 Manual initialization of linear actuators

See detailed operating instructions for information on manual initialization of linear actuators.

5.7 Commissioning part-turn actuators

5.7.1 Preparing part-turn actuators for commissioning

Note

Setting of the adjustment angle

The usual adjustment angle for part-turn actuators is 90°.

- Set the transmission ratio selector in the positioner to 90°.
-

Requirements

The following conditions must be fulfilled before activating the initialization:

1. You have installed the positioner for the part-turn actuators using the suitable mounting kit.
2. You have connected the actuator and the positioner to the pneumatic lines.
3. Pneumatic auxiliary power is supplied to the positioner.
4. The positioner has been connected to a suitable current or voltage source.

Setting the actuator

1. The positioner is in the "P manual mode". The current potentiometer voltage P in percent is shown on the upper line in the display. "NOINI" blinks in the lower line of the display. Examples of corresponding displays are given below:



2. Check whether the mechanical unit can be moved freely in the entire travel range. Move the drive to the respective end position for this purpose using the ▲ or ▼ button.

Note

End position

By simultaneously pressing the ▲ and ▼ buttons, you reach the end position faster.

3. After checking, move the actuator to a central position. This accelerates the initialization process.

5.7.2 Automatic initialization of part-turn actuators

Requirements

The following conditions must be fulfilled before activating the automatic initialization:

1. The travel range of the actuator can be passed through completely.
2. The actuator shaft is at a central position.

Initializing the part-turn actuator automatically

Note

Interrupting initialization

An ongoing initialization can be interrupted at any time. To do this, press . The settings configured until then are retained.

All parameters are reset to factory settings only if you have explicitly activated the preset settings in the "PRST" parameter.

5.7 Commissioning part-turn actuators

1. Switch to the "Configuration" mode. To do this, press the  button for at least 5 seconds until the display shows the following:



2. Use the  button to change from linear actuator to part-turn actuator until the display shows the following:



3. Call the "2.YAGL" parameter. To do this, briefly press the  button. This parameter has already been set to 90° automatically. The display shows the following:



4. Call the "4.INITA" parameter. To do this, briefly press the  button. The display shows the following:



5. Start the initialization process. To do this, press the  button for at least 5 seconds until the display shows the following:



The positioner runs through five initialization steps during the automatic initialization process. Displays for the initialization steps from "RUN 1" to "RUN 5" are shown in the lower line on the display. The initialization process depends on the actuator used, and takes up to 15 minutes.

6. The following display indicates that the automatic initialization is complete. The total angle of rotation of the actuator is shown on the upper line on the display:



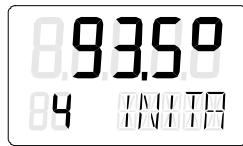

Aborting the automatic initialization process

1. Press the  button. The display shows the following:



The positioner is in the "Configuration" mode.

2. Exit the "Configuration" mode. To do this, press the  button for at least 5 seconds. The software status is displayed. After releasing the  button, the positioner is in "P manual mode". The part-turn actuator is not initialized.

5.7.3 Manual initialization of part-turn actuators

See detailed operating instructions for information on manual initialization of part-turn actuators.

Service and maintenance

6.1 Basic safety instructions

 WARNING
Impermissible repair of the device <ul style="list-style-type: none">• Repair must be carried out by Siemens authorized personnel only.

 WARNING
Dust layers above 5 mm <p>Risk of explosion in hazardous areas. Device may overheat due to dust build up.</p> <ul style="list-style-type: none">• Remove dust layers in excess of 5 mm.

NOTICE
Penetration of moisture into the device <p>Device damage.</p> <ul style="list-style-type: none">• Make sure when carrying out cleaning and maintenance work that no moisture penetrates the inside of the device.

 CAUTION
Releasing button lock <p>Improper modification of parameters could influence process safety.</p> <ul style="list-style-type: none">• Make sure that only authorized personnel may cancel the button locking of devices for safety-related applications.

Cleaning the enclosure

- Clean the outside of the enclosure with the inscriptions and the display window using a cloth moistened with water or a mild detergent.
- Do not use any aggressive cleansing agents or solvents, e.g. acetone. Plastic parts or the painted surface could be damaged. The inscriptions could become unreadable.

 WARNING
Electrostatic charge
Risk of explosion in hazardous areas if electrostatic charges develop, for example, when cleaning plastic surfaces with a dry cloth.
<ul style="list-style-type: none">• Prevent electrostatic charging in hazardous areas.

6.2 Cleaning of the screens

The positioner is maintenance-free to a large extent. Screens are installed in the pneumatic connections of the positioners to protect them from rough dirt particles. If there are dirt particles in the pneumatic auxiliary power supply, they damage the screens and hamper the function of the positioner. Clean the screens as described in the following two chapters.

6.2.1 Positioners with polycarbonate enclosure 6DR5..0, aluminum enclosure 6DR5..3, and flameproof aluminum enclosure 6DR5..5

 DANGER
Risk of explosion due to electrostatic charge
Electrostatic charges develop, for example, when cleaning the positioner in the polycarbonate enclosure with a dry cloth.
It is imperative you avoid electrostatic charges in the hazardous environment.

Procedure for removal and cleaning of the screens

1. Disconnect the pneumatic auxiliary power supply.
2. Remove the lines.
3. Unscrew the cover of the polycarbonate enclosure 6DR5..0 or aluminum enclosure 6DR5..3.
4. Unscrew the three screws on the pneumatic terminal strip.
5. Remove the screens and O-rings behind the terminal strip.
6. Clean the screens, e.g. using compressed air.

Procedure for installation of the screens

 **CAUTION**

Damage to the polycarbonate enclosure

- The enclosure is damaged due to screwing in the self-tapping screws improperly.
- Ensure that the available thread pitches are used.
- Turn the screws anticlockwise until they engage noticeably in the thread pitch.
- Tighten the self-tapping screws only after they have engaged.

1. Insert the screens into the recesses of the enclosure.
2. Place the O-rings on the screens.
3. Insert the pneumatic terminal strip.
4. Tighten the three screws. Note: With the polycarbonate enclosure, the screws are self-tapping.
5. Place the cover and tighten it.
6. Reconnect the pipelines and feed the pneumatic power supply.

6.2.2 Positioners with stainless steel enclosure 6DR5..2, flameproof stainless steel enclosure 6DR5..6, and narrow aluminum enclosure 6DR5..1

Removal, cleaning and installation of the screens

1. Disconnect the pneumatic auxiliary power supply.
2. Remove the pipelines.
3. Remove the metal screen from the bores carefully.
4. Clean the metal screens, e.g. using compressed air.
5. Insert the screens.
6. Connect the pipelines again.
7. Feed the pneumatic auxiliary power supply.

6.3 Maintenance and repair work

 WARNING
Impermissible accessories and spare parts
Risk of explosion in areas subject to explosion hazard.
<ul style="list-style-type: none">• Only use original accessories or original spare parts.• Observe all relevant installation and safety instructions described in the instructions for the device or enclosed with the accessory or spare part.

 WARNING
Improper connection after maintenance
Risk of explosion in areas subject to explosion hazard.
<ul style="list-style-type: none">• Connect the device correctly after maintenance.• Close the device after maintenance work.
Refer to Electrical connection (Page 34).

6.3.1 Repair/Upgrading

Send defective devices to the repairs department, together with information on the malfunction and the cause of the malfunction. When ordering replacement devices, please provide the serial number of the original device. You can find the serial number on the nameplate.

6.4 Return procedure

Enclose the bill of lading, return document and decontamination certificate in a clear plastic pouch and attach it firmly to the outside of the packaging. Any devices/replacement parts which are returned without a decontamination declaration will be cleaned at your expense before further processing. For further details refer to the operating instructions.

See also

Return document (<http://www.siemens.com/processinstrumentation/returngoodsnote>)

Decontamination declaration (<http://www.siemens.com/sc/declarationofdecontamination>)

6.5 Disposal

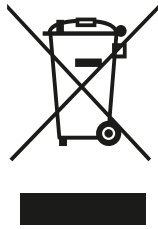

Devices described in this manual should be recycled. They may not be disposed of in the municipal waste disposal services according to the Directive 2012/19/EC on waste electronic and electrical equipment (WEEE).

Devices can be returned to the supplier within the EC, or to a locally approved disposal service for eco-friendly recycling. Observe the specific regulations valid in your country.

Further information about devices containing batteries can be found at: Information on battery/product return (WEEE) (<https://support.industry.siemens.com/cs/document/109479891/>)

Technical data

7.1 All device versions

7.1.1 Operating conditions

Rated conditions	
Ambient conditions	For use indoors and outdoors.
Ambient temperature	In hazardous areas, observe the maximum permissible ambient temperature corresponding to the temperature class.
<ul style="list-style-type: none"> Permissible ambient temperature for operation ²⁾³⁾ 	-30 ... +80 °C (-22 ... +176 °F)
<ul style="list-style-type: none"> Height 	2000 m above sea level. At altitudes greater than 2000 m above sea level, use a suitable power supply.
<ul style="list-style-type: none"> Relative humidity 	0 ... 100%
Degree of pollution	2
Overvoltage category	II
Degree of protection ¹⁾	IP66 to IEC/EN 60529 / NEMA 4X
Mounting position	Any; in wet environment, pneumatic connections and outlet opening not upward
Vibration resistance	
<ul style="list-style-type: none"> Harmonic oscillations (sine) according to EN 60068-2-6/10.2008 	3.5 mm (0.14"), 2 ... 27 Hz, 3 cycles/axle 98.1 m/s ² (321.84 ft/s ²), 27 ... 300 Hz, 3 cycles/axle
<ul style="list-style-type: none"> Bumping (half-sine) according to EN 60068-2-27/02.2010 	150 m/s ² (492 ft/s ²), 6 ms, 1000 shocks/axle
<ul style="list-style-type: none"> Noise (digitally controlled) according to EN 60068-2-64/04.2009 	10 ... 200 Hz; 1 (m/s ²) ² /Hz (3.28 (ft/s ²) ² /Hz) 200 ... 500 Hz; 0.3 (m/s ²) ² /Hz (0.98 (ft/s ²) ² /Hz) 4 hours/axle
<ul style="list-style-type: none"> Recommended range of continuous operation of the entire control valve 	≤ 30 m/s ² (98.4 ft/s ²) without resonance peak
Climate class	
<ul style="list-style-type: none"> Storage 	1K5, but -40 ... +80°C (1K5, but -40 ... +176°F)
<ul style="list-style-type: none"> Transport 	2K4, but -40 ... +80°C (2K4, but -40 ... +176°F)

¹⁾ Max. impact energy 1 Joule for enclosure with inspection window 6DR5..0 and 6DR5..1 or max. 2 Joule for 6DR5..3

²⁾ At ≤ -10 °C (≤ 14 °F) the display refresh rate of the indicator is limited. When using position feedback module, only T4 is permissible.

³⁾ The following applies to order suffix (order code) **-Z M40**: -40 ... +80 °C (-40 ... +176°F)

7.1.2 Pneumatic data

Pneumatic data	
Auxiliary power (air supply)	Compressed air, carbon dioxide (CO ₂), nitrogen (N), noble gases or cleaned natural gas
• Pressure ¹⁾	1.4 ... 7 bar (20.3 ... 101.5 psi)
Air quality to ISO 8573-1	
• Solid particulate size and density	Class 3
• Pressure dew point	Class 3 (min. 20 K (36 °F) below ambient temperature)
• Oil content	Class 3
Unrestricted flow (DIN 1945)	
• Inlet air valve (ventilate actuator) ²⁾	
2 bar (29 psi)	4.1 Nm ³ /h (18.1 USgpm)
4 bar (58 psi)	7.1 Nm ³ /h (31.3 USgpm)
6 bar (87 psi)	9.8 Nm ³ /h (43.1 USgpm)
• Exhaust valve (deerate actuator for all versions except fail in place) ²⁾	
2 bar (29 psi)	8.2 Nm ³ /h (36.1 USgpm)
4 bar (58 psi)	13.7 Nm ³ /h (60.3 USgpm)
6 bar (87 psi)	19.2 Nm ³ /h (84.5 USgpm)
• Exhaust valve (deerate actuator for fail in place version)	
2 bar (29 psi)	4.3 Nm ³ /h (19.0 USgpm)
4 bar (58 psi)	7.3 Nm ³ /h (32.2 USgpm)
6 bar (87 psi)	9.8 Nm ³ /h (43.3 USgpm)
Valve leakage	< 6·10 ⁻⁴ Nm ³ /h (0.0026 USgpm)
Throttle ratio	Adjustable up to ∞: 1
Auxiliary power consumption in the controlled state	< 3.6·10 ⁻² Nm ³ /h (0.158 USgpm)
Sound pressure level	L _{A,eq} < 75 dB L _{A,max} < 80 dB

¹⁾ The following applies to fail in place: 3 ... 7 bar (43.5 ... 101.5 psi)

²⁾ When using device versions Ex d (6DR5..5-... and 6DR5..6-...) Values are reduced by approximately 20%.

7.1.3 Construction

Construction	
How does it work?	
• Range of stroke (linear actuator)	3 ... 130 mm (0.12 ... 5.12") (angle of rotation of the positioner shaft 16 ... 90°)
• Angle of rotation (part-turn actuator)	30 to 100°
Mounting method	

Construction	
• On the linear actuator	Using mounting kit 6DR4004-8V and, where necessary, an additional lever arm 6DR4004-8L on actuators according to IEC 60534-6-1 (NAMUR) with a fin, columns, or a plane surface.
• On the part-turn actuator	Using mounting kit 6DR4004-8D on actuators with mounting plane according to VDI/VDE 3845 and IEC 60534-6-2: The required mount must be provided on the actuator-side.
Weight, positioner without option modules or accessories	
• 6DR5..0 Glass-fiber reinforced polycarbonate enclosure	Approx. 0.9 kg (1.98 lb)
• 6DR5..1 aluminum enclosure, narrow	Approx. 1.3 kg (2.86 lb)
• 6DR5..2 stainless steel enclosure	Approx. 3.9 kg (8.6 lb)
• 6DR5..3 aluminum enclosure	Approx. 1.6 kg (3.53 lb)
• 6DR5..5 aluminum enclosure, flameproof	Approx. 5.2 kg (11.46 lb)
• 6DR5..6 stainless steel enclosure, flameproof	Approx. 8.4 kg (18.5 lb)
Material	
• Enclosure	
6DR5..0 polycarbonate	Glass-fiber reinforced polycarbonate (PC)
6DR5..1 aluminum, narrow	GD AlSi12
6DR5..2 stainless steel	Austenitic stainless steel 316 Cb, mat. No. 1.4581
6DR5..3 aluminum	GD AlSi12
6DR5..5 aluminum, flameproof	GK AlSi12
6DR5..6 stainless steel enclosure, flameproof	Austenitic stainless steel 316 L, mat. no. 1.4409
• Pressure gauge block	Aluminum AlMgSi, anodized or stainless steel 316
Versions	
• In the polycarbonate enclosure 6DR5..0	Single-acting and double-acting
• In aluminum enclosure 6DR5..1	Single-acting
• In aluminum enclosures 6DR5..3 and 6DR5..5	Single-acting and double-acting
• In stainless steel enclosures 6DR5..2 and 6DR5..6	Single-acting and double-acting
Torques	
• Part-turn actuator fixing screws DIN 933 M6x12-A2	5 Nm (3.7 ft lb)
• Linear actuator fixing screws DIN 933 M8x16-A2	12 Nm (8.9 ft lb)
• Gland pneumatic G $\frac{1}{4}$	15 Nm (11.1 ft lb)
• Gland pneumatic $\frac{1}{4}$ " NPT	
Without sealant	12 Nm (8.9 ft lb)
With sealant	6 Nm (4.4 ft lb)
• Cable glands	
Screw-in torque for plastic gland in all enclosures	4 Nm (3 ft lb)
Screw-in torque for cable gland made of metal/stainless steel in polycarbonate enclosure	6 Nm (4.4 ft lb)
Screw-in torque for metal/stainless steel glands in aluminum/stainless steel enclosure	6 Nm (4.4 ft lb)

Technical data

7.1 All device versions

Construction	
Screw-in torque for NPT adapter made of metal/stainless steel in polycarbonate enclosure	8 Nm (5.9 ft lb)
Screw-in torque for NPT adapter made of metal/stainless steel in aluminum/stainless steel enclosure	15 Nm (11.1 ft lb)
Screw-in torque for NPT gland in the NPT adapter NOTE: To avoid damage to the device, the NPT adapter must be held in place while the NPT gland is screwed into the NPT adapter.	68 Nm (50 ft lb)
Tightening torque for union nut made of plastic	2.5 Nm (1.8 ft lb)
Tightening torque for union nut made of metal/stainless steel	4 Nm (3 ft lb)
Manometer	
• Degree of protection	
Manometer made of plastic	IP31
Manometer, steel	IP44
Manometer made of stainless steel 316	IP54
• Vibration resistance	In accordance with DIN EN 837-1
Connections, electrical	
• Screw terminals	2.5 mm ² AWG30-14
• Cable gland	Without Ex protection as well as with Ex i: M20x1.5 or ½-14 NPT With explosion protection Ex d: Ex d certified M20x1.5, ½-14 NPT or M25x1.5
Connections, pneumatic	Female thread G¼ or ¼-18 NPT

7.1.4 Controller

Controller	
Control unit	
• Five-point controller	Adaptive
• Dead zone	
dEbA = auto	Adaptive
dEbA = 0.1 ... 10 %	Can be set as fixed value
Analog-to-digital converter	
• Scanning time	10 ms
• Resolution	≤ 0,05 %
• Transmission error	≤ 0,2 %
• Temperature influence	≤ 0.1 %/10 K (≤ 0.1 %/18 °F)

7.1.5 Certificates, approvals, explosion protection

Certificates and approvals	
Classification according to pressure equipment directive (PED 2014/68/EU)	For fluid group 1 gases; fulfills requirements according to article 4, paragraph 3 (good engineering practice SEP)
CE conformity	The applicable directives and applied standards with their revision levels can be found in the EU declaration of conformity on the Internet.
UL conformity	You can find the appropriate "Standard(s) for Safety", including the relevant versions, in the UL-CERTIFICATE OF COMPLIANCE on the Internet.

See also

Certificates (<http://www.siemens.com/processinstrumentation/certificates>)

Explosion protection

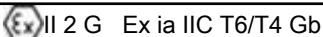
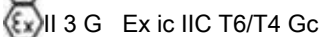
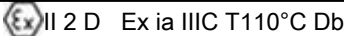
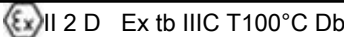
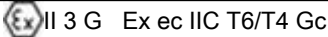
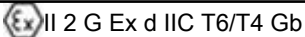
Explosion protection	Ex markings	
Explosion protection in accordance with	ATEX/IECEX	FM/CSA
Intrinsic safety "i", "IS"		
<ul style="list-style-type: none"> 6DR5..0/1/2/3-0E; 6DR5..1/2/3-0F/K 	 	CI I Zn 1 AEx ib IIC IS CI I Div 1 Gp A-D
<ul style="list-style-type: none"> 6DR5..1/2/3-0F 	-	CI I Zn 1 AEx ib IIC IS CI I Div 1 Gp A-D
<ul style="list-style-type: none"> 6DR5..0-0E/F/K 		CI I Zn 1 AEx ib IIC IS CI I, II, III Div 1 Gp A-G Zn 21 AEx ib Db IIIC T110°C
Dust, protection by means of enclosure "t", "DIP"		
<ul style="list-style-type: none"> 6DR5..1/2/3-0D/K; 6DR5..6-0E 		DIP CI II, III Div 1 Gp E-G Zn 21 AEx tb IIIC T100°C
For use in Zone 2 / DIV.2: "ec", "nA", "ic"		
<ul style="list-style-type: none"> 6DR5..1/2/3-0F/G/K 		CI I Zn 2 AEx nA IIC NI CI I Div 2 Gp A-D
<ul style="list-style-type: none"> 6DR5..0-0F 	-	CI I Zn 2 AEx nA IIC NI CI I Div 2 Gp A-D
Flameproof enclosure encapsulation "d", "XP"		
<ul style="list-style-type: none"> 6DR5..5/6 		FM CI I Zn 1 AEx d IIC XP CI I Div 1 Gp A-D CSA CI I Zn 1 AEx d IIC XP CI I Div 1 Gp C-D

Breakdown of the article numbers for assignment of the maximum permissible ambient temperature ranges

6DR5ayb-	0cdef-	g..h-	Z jjj
a = 0, 2, 5, 6	c = E, G, D, F, K	g = 0, 2, 6, 7, 8	A20, A40, C20, D53, D54, D55, D56, F01, K**, L1A, M40, R**, S**, Y** * = any character
y = 1, 2	d = G, N, M, P, R, S	h = 0, 1, 2, 3, 4, 9	
b = 0, 1, 2, 3	e = 0, 1, 2, 3		
	f = 0, 1, 2, 3		

Maximum permissible ambient temperature ranges with types of protection Ex ia, Ex ic, Ex nA and Ex ec

Explosion protection in accordance with	ATEX/IECEX	FM/CSA
<ul style="list-style-type: none"> 6DR5ayb-0cdef-g.Ah-Z ... 	T4: $-30 \leq T_a \leq +80 \text{ °C}$ ($-22 \leq T_a \leq +176 \text{ °F}$) T6: $-30 \leq T_a \leq +50 \text{ °C}$ ($-22 \leq T_a \leq +122 \text{ °F}$)	
<ul style="list-style-type: none"> 6DR5ayb-0cdef-g.Ah-Z M40 	T4: $-40 \leq T_a \leq +80 \text{ °C}$ ($-40 \leq T_a \leq +176 \text{ °F}$) T6: $-40 \leq T_a \leq +50 \text{ °C}$ ($-40 \leq T_a \leq +122 \text{ °F}$)	
<ul style="list-style-type: none"> 6DR5ayb-0cdef-g.Ah-Z ... With the data (a = 0,2; e = 0,1,2,3; f = 0,2) 	T4: $-30 \leq T_a \leq +80 \text{ °C}$ ($-22 \leq T_a \leq +176 \text{ °F}$) T6: $-30 \leq T_a \leq +60 \text{ °C}$ ($-22 \leq T_a \leq +140 \text{ °F}$)	
<ul style="list-style-type: none"> 6DR5ayb-0cdef-g.Ah-Z M40 With the data (a = 0,2; e = 0,1,2,3; f = 0,2) 	T4: $-40 \leq T_a \leq +80 \text{ °C}$ ($-40 \leq T_a \leq +176 \text{ °F}$) T6: $-40 \leq T_a \leq +60 \text{ °C}$ ($-40 \leq T_a \leq +140 \text{ °F}$)	
Position feedback module (already fitted or can be retrofitted)		
<ul style="list-style-type: none"> Already fitted: 6DR5ayb-0cdef-g.Ah-Z ... with the data (f = 1 or 3) Can be retrofitted 6DR4004-6J 	T4: $-30 \leq T_a \leq +80 \text{ °C}$ ($-22 \leq T_a \leq +176 \text{ °F}$)	
<ul style="list-style-type: none"> Already fitted and can be retrofitted: 6DR5ayb-0cdef-g.Ah-Z M40 with the data (f = 1 or 3) 	T4: $-40 \leq T_a \leq +80 \text{ °C}$ ($-40 \leq T_a \leq +176 \text{ °F}$)	
Option modules		
<ul style="list-style-type: none"> Non contacting sensor (NCS) 6DR4004-6N...-0-... 	T4: $-40 \leq T_a \leq +90 \text{ °C}$ ($-40 \leq T_a \leq +194 \text{ °F}$) T6: $-40 \leq T_a \leq +70 \text{ °C}$ ($-40 \leq T_a \leq +158 \text{ °F}$)	T4: $-40 \leq T_a \leq +85 \text{ °C}$ ($-40 \leq T_a \leq +185 \text{ °F}$) T6: $-40 \leq T_a \leq +70 \text{ °C}$ ($-40 \leq T_a \leq +158 \text{ °F}$)
<ul style="list-style-type: none"> External position detection system C73451-A430-D78 or 6DR4004-1ES 	T4: $-40 \leq T_a \leq +90 \text{ °C}$ ($-40 \leq T_a \leq +194 \text{ °F}$) T6: $-40 \leq T_a \leq +60 \text{ °C}$ ($-40 \leq T_a \leq +140 \text{ °F}$)	T4: $-40 \leq T_a \leq +85 \text{ °C}$ ($-40 \leq T_a \leq +185 \text{ °F}$) T6: $-40 \leq T_a \leq +60 \text{ °C}$ ($-40 \leq T_a \leq +140 \text{ °F}$)

Maximum permissible ambient temperature ranges with type of protection Ex t

Explosion protection in accordance with	ATEX/IECEX	FM/CSA
• 6DR5ayb-0cdef-g.Ah-Z ... with the data (c = D or K)		$-30 \leq T_a \leq +80 \text{ °C}$ ($-22 \leq T_a \leq +176 \text{ °F}$)
• 6DR5ayb-0cdef-g.Ah-Z M40 with the data (c= D or K)		$-40 \leq T_a \leq +80 \text{ °C}$ ($-40 \leq T_a \leq +176 \text{ °F}$)

7.2 Natural gas as actuator medium

Introduction

Note when using an actuator with natural gas that this can escape at the following points:

- At the exhaust air outlet with sound absorber.
- At the enclosure vent.
- At the control air outlet near the pneumatic connections.

Note

Exhaust air outlet with a sound absorber

The positioner is supplied as standard with a sound absorber. To provide an outlet for the exhaust air, replace the sound absorber by a G¼ pipe coupling.

Enclosure ventilation and control air outlet

Enclosure ventilation and control air outlet cannot be collected and channeled off.

Please refer to the following table for the maximum ventilation values.

Maximum values for escaping natural gas

Ventilation process	Operating mode	6DR5.1.-E...	6DR5.2.-E...
		Single-acting	Double-acting
		[NI/min]	[NI/min]
Ventilation of the enclosure volume. Purge air switch is at "IN":	Operation, typical	0.14	0.14
	Operation, max.	0.60	0.60
	Error case, max.	60.0	60.0
Ventilation via the control air outlet near the pneumatic connections:	Operation, typical	1.0	2.0
	Operation, max.	8.9	9.9
	Error case, max.	66.2	91.0

7.3 SIPART PS2 with and without HART

Ventilation process	Operating mode	6DR5.1.-.E...	6DR5.2.-.E...
		Single-acting	Double-acting
		[NI/min]	[NI/min]
Ventilation through the exhaust air outlet with a sound absorber	Operation, max.	358.2 ¹⁾	339 ¹⁾
	Error case, max.		
Volume	Max. [l]	1.26	1.23

1) Depending on the actuating pressure and volume of the actuator as well as the frequency of control. The maximum flow rate is 470 NI/min at a differential pressure of 7 bar.

7.3 SIPART PS2 with and without HART

7.3.1 Electrical data

	Basic electronics without explosion protection	Basic electronics with explosion protection Ex d	Basic electronics with explosion protection Ex "ia"	Basic electronics with explosion protection Ex "ic", "ec", "t", "nA"
Current input_w				
• Rated signal range			0/4 ... 20 mA	
• Test voltage			840 V DC, 1 s	
• Binary input BIN1 (terminals 9/10; galvanically connected to basic device)		Suitable only for floating contact; max. contact load < 5 µA with 3 V		
2-wire connection				
6DR50.. and 6DR53.. Without HART				
6DR51.. and 6DR52.. With HART				
Current to maintain the auxiliary power			≥ 3.6 mA	
Required load voltage U _B (corresponds to Ω at 20 mA)				
• Without HART (6DR50..)				
Typical	6.36 V (= 318 Ω)	6.36 V (= 318 Ω)	7.8 V (= 390 Ω)	7.8 V (= 390 Ω)
Max.	6.48 V (= 324 Ω)	6.48 V (= 324 Ω)	8.3 V (= 415 Ω)	8.3 V (= 415 Ω)
• Without HART (6DR53..)				
Typical	7.9 V (= 395 Ω)	-	-	-
Max.	8.4 V (= 420 Ω)	-	-	-
• With HART (6DR51..)				
Typical	6.6 V (= 330 Ω)	6.6 V (= 330 Ω)	-	-

7.3 SIPART PS2 with and without HART

	Basic electronics without explosion protection	Basic electronics with explosion pro- tection Ex d	Basic electronics with explosion pro- tection Ex "ia"	Basic electronics with explosion pro- tection Ex "ic", "ec", "t", "nA"
Max.	6.72 V (= 336 Ω)	6.72 V (= 336 Ω)	-	-
• With HART (6DR52..)				
Typical	-	8.4 V (= 420 Ω)	8.4 V (= 420 Ω)	8.4 V (= 420 Ω)
Max.	-	8.8 V (= 440 Ω)	8.8 V (= 440 Ω)	8.8 V (= 440 Ω)
• Static destruction limit	± 40 mA	± 40 mA	-	-
Effective inner capacitance C_i	-	-		
• Without HART	-	-	11 nF	"ic": 11 nF
• With HART	-	-	11 nF	"ic": 11 nF
Effective inner inductance L_i	-	-		
• Without HART	-	-	207 μH	"ic": 207 μH
• With HART	-	-	310 μH	"ic": 310 μH
For connecting to circuits with the following peak values	-	-	$U_i = 30\text{ V}$ $I_i = 100\text{ mA}$ $P_i = 1\text{ W}$	"ic": $U_i = 30\text{ V}$ $I_i = 100\text{ mA}$ "ec"/"t"/"nA": $U_n \leq 30\text{ V}$ $I_n \leq 100\text{ mA}$

3-/4-wire connection

6DR52.. With HART, explosion-protected

6DR53.. Without HART, not explosion-protected

Load voltage at 20 mA	≤ 0.2 V (= 10 Ω)	≤ 0.2 V (= 10 Ω)	≤ 1 V (= 50 Ω)	≤ 1 V (= 50 Ω)
Auxiliary power U_H	18 ... 35 V DC	18 ... 35 V DC	18 ... 30 V DC	18 ... 30 V DC
• Current consumption I_H			$(U_H - 7.5\text{ V})/2.4\text{ k}\Omega$ [mA]	
For connecting to circuits with the following peak values	-	-	$U_i = 30\text{ V}$ $I_i = 100\text{ mA}$ $P_i = 1\text{ W}$	"ic": $U_i = 30\text{ V}$ $I_i = 100\text{ mA}$ "ec"/"t"/"nA": $U_n \leq 30\text{ V}$ $I_n \leq 100\text{ mA}$
Effective inner capacitance C_i	-	-	22 nF	22 nF
Effective inner inductance L_i	-	-	0.12 mH	0.12 mH
Galvanic isolation	Between U_H and I_W	Between U_H and I_W	Between U_H and I_W (2 intrinsically safe circuits)	Between U_H and I_W

7.3.2 Communication (HART)

HART communication	
HART version	7
PC parameter assignment software	SIMATIC PDM; supports all device objects. The software is not included in the scope of delivery.

7.4 SIPART PS2 with PROFIBUS PA/with FOUNDATION Fieldbus

7.4.1 Electrical data

	Basic device without explosion protection	Basic device with explosion protection Ex d	Basic device with explosion protection Ex "ia"	Basic device with explosion protection Ex "ic", "ec", "t", "nA"
Auxiliary power supply bus circuit	Bus-powered			
Bus voltage	9 ... 32 V	9 ... 32 V	9 ... 24 V	9 ... 32 V
For connecting to circuits with the following peak values				
<ul style="list-style-type: none"> Bus connector with FISCO supply unit 	-	-	$U_i = 17.5 \text{ V}$ $I_i = 380 \text{ mA}$ $P_i = 5.32 \text{ W}$	"ic": $U_i = 17.5 \text{ V}$ $I_i = 570 \text{ mA}$ "ec"/"t"/"nA": $U_n \leq 32 \text{ V}$
<ul style="list-style-type: none"> Bus connector with barrier 			$U_i = 24 \text{ V}$ $I_i = 250 \text{ mA}$ $P_i = 1.2 \text{ W}$	"ic": $U_i = 32 \text{ V}$ "ec"/"t"/"nA": $U_n \leq 32 \text{ V}$
Effective inner capacitance C_i	-	-	Negligible	Negligible
Effective inner inductance L_i	-	-	8 μH	"ic": 8 μH
Current consumption	11.5 mA \pm 10 %			
Additional fault current	0 mA			
Safety shutdown can be activated using "Jumper" (terminals 81 and 82)	Electrically isolated from bus circuit and binary input			
<ul style="list-style-type: none"> Input resistance 	> 20 k Ω			
<ul style="list-style-type: none"> Signal status "0" (shutdown active) 	0 ... 4.5 V or unused			
<ul style="list-style-type: none"> Signal status "1" (shutdown inactive) 	13 ... 30 V			

7.4 SIPART PS2 with PROFIBUS PA/with FOUNDATION Fieldbus

	Basic device without explosion protection	Basic device with explosion protection Ex d	Basic device with explosion protection Ex "ia"	Basic device with explosion protection Ex "ic", "ec", "t", "nA"
<ul style="list-style-type: none"> For connecting to power source with the following peak values 	-	-	$U_i = 30 \text{ V}$ $I_i = 100 \text{ mA}$ $P_i = 1 \text{ W}$	"ec"/"nA": $U_n \leq 30 \text{ V}$ $I_n \leq 100 \text{ mA}$ "ic": $U_i = 30 \text{ V}$ $I_i = 100 \text{ mA}$
<ul style="list-style-type: none"> Effective internal capacitance and inductance 	-	-	Negligible	Negligible
Binary input BE1 (terminals 9 and 10) electrically connected to the bus circuit		Jumpered or connection to switch contact. Suitable only for floating contact; max. contact load $< 5 \mu\text{A}$ with 3 V		
Galvanic isolation				
<ul style="list-style-type: none"> For basic device without Ex protection and for basic device with Ex d 	Galvanic isolation between the basic device and the input for safety shutdown and the outputs of option modules.			
<ul style="list-style-type: none"> For basic device Ex "ia" 	The basic device, the input for safety shutdown, and the outputs of option modules are individual intrinsically safe circuits.			
<ul style="list-style-type: none"> For basic device Ex "ic", "ec", "t", "nA" 	Galvanic isolation between the basic device and the input for safety shutdown and the outputs of option modules.			
Test voltage	DC 840 V, 1 s			

7.4.2 PROFIBUS PA communication

Communication	Layers 1 + 2 as per PROFIBUS PA, transmission technique as per IEC 1158-2; slave function layer 7 (protocol layer) as per PROFIBUS DP, standard EN 50170 with the extended PROFIBUS functionality (all data is acyclic, manipulated variable, feedbacks and statuses are additionally cyclic)
C2 connections	Four connections with the master class 2 are supported; automatic connection termination 60 s after interruption in communication
Device profile	PROFIBUS PA profile B, version 3.0; over 150 objects
Response time for a master telegram	Typically, 10 ms
Device address	126 (in the as-delivered condition)
PC parameter assignment software	SIMATIC PDM; supports all device objects. The software is not included in the scope of delivery.

7.4.3 FOUNDATION Fieldbus communication

Communication group and class	According to the technical specification of the Fieldbus Foundation for H1 communication
Function blocks	Group 3, Class 31PS (Publisher Subscriber) 1 resource block (RB2) 1 analog output function block (AO) 1 PID function block (PID) 1 transducer block (standard advanced positioner valve)
Execution times of the blocks	AO: 60 ms PID: 80 ms
Physical layer profile	123, 511
FF registration	Tested with ITK 5.0
Device address	22 (when delivered)

7.5 Option modules

7.5.1 Alarm module

	Without explosion protection or suitable for use in the SIPART PS2 Ex d	With Ex protection Ex "ia"	With Ex protection Ex "ic", "ec", "t", "nA"
Alarm module	6DR4004-8A	6DR4004-6A	6DR4004-6A
3 binary output circuits			
<ul style="list-style-type: none"> Alarm output A1: Terminals 41 and 42 Alarm output A2: Terminals 51 and 52 Fault message output: Terminals 31 and 32 			
• Auxiliary voltage U_H	≤ 35 V and the current consumption is to be limited to < 25 mA	-	-
• Signal status			
High (not addressed)	Conductive, $R = 1$ k Ω , $+3/-1$ % *)	≥ 2.1 mA	≥ 2.1 mA
Low *) (addressed)	Deactivated, $I_R < 60$ μ A	≤ 1.2 mA	≤ 1.2 mA
*) The status is also Low if the basic device is faulty or without a auxiliary power.	*) When using in the flame-proof housing, the current consumption must be restricted to 10 mA per output.	Switching thresholds for supply as per EN 60947-5-6: $U_H = 8.2$ V, $R_i = 1$ k Ω	Switching thresholds for supply as per EN 60947-5-6: $U_H = 8.2$ V, $R_i = 1$ k Ω
• For connecting to circuits with the following peak values	-	$U_i = 15$ V DC $I_i = 25$ mA $P_i = 64$ mW	"ic": $U_i = 15$ V DC $I_i = 25$ mA "ec"/"t"/"nA": $U_n \leq 15$ V DC

	Without explosion protection or suitable for use in the SIPART PS2 Ex d	With Ex protection Ex "ia"	With Ex protection Ex "ic", "ec", "t", "nA"
Effective internal capacitance	-	$C_i = 5.2 \text{ nF}$	$C_i = 5.2 \text{ nF}$
Effective internal inductance	-	$L_i = \text{negligibly small}$	$L_i = \text{negligibly small}$
1 binary input circuit			
<ul style="list-style-type: none"> Binary input BI2: Terminals 11 and 12, terminals 21 and 22 (jumper) Galvanically connected with the basic device 			
Signal status 0		Floating contact, open	
Signal status 1		Floating contact, closed	
Contact load		3 V, 5 μA	
<ul style="list-style-type: none"> Electrically isolated from the basic device 			
Signal status 0		$\leq 4.5 \text{ V}$ or open	
Signal status 1		$\geq 13 \text{ V}$	
Internal resistance		$\geq 25 \text{ k}\Omega$	
Static destruction limit	$\pm 35 \text{ V}$	-	-
Connecting to circuits with the following peak values	-	$U_i = \text{DC } 25.2 \text{ V}$	"ic": $U_i = \text{DC } 25.2 \text{ V}$ "ec"/"t"/"nA": $U_n \leq \text{DC } 25.5 \text{ V}$
Effective internal capacitance	-	$C_i = \text{negligibly small}$	$C_i = \text{negligibly small}$
Effective internal inductance	-	$L_i = \text{negligibly small}$	$L_i = \text{negligibly small}$
Galvanic isolation	The three outputs, the BI2 input and the basic device are galvanically isolated from each other.		
Test voltage	DC 840 V, 1 s		

7.5.2 Position feedback module

	Without explosion protection or suitable for use in the SIPART PS2 Ex d	With Ex protection Ex ia (use only in temperature class T4)	With Ex protection Ex "ic", "ec", "t", "nA"
Position feedback module	6DR4004-8J	6DR4004-6J	6DR4004-6J
Direct current output for position feedback			
1 current output, terminals 61 and 62			
2-wire connection			
Rated signal range	4 ... 20 mA, short-circuit proof		
Dynamic range	3.6 ... 20.5 mA		
Auxiliary voltage U_H	+12 ... +35 V	+12 ... +30 V	+12 ... +30 V
External load R_B [k Ω]	$\leq (U_H [\text{V}] - 12 \text{ V})/I [\text{mA}]$		

	Without explosion protection or suitable for use in the SIPART PS2 Ex d	With Ex protection Ex ia (use only in temperature class T4)	With Ex protection Ex "ic", "ec", "t", "nA"
Transmission error		≤ 0.3%	
Temperature influence		≤ 0.1%/10 K (≤ 0.1%/18 °F)	
Resolution		≤ 0.1%	
Residual ripple		≤ 1 %	
For connecting to circuits with the following peak values		U _i = DC 30 V I _i = 100 mA P _i = 1 W	"ic": U _i = DC 30 V I _i = 100 mA "ec"/"t"/"nA": U _n ≤ DC 30 V I _n ≤ 100 mA P _n ≤ 1 W
Effective internal capacitance	-	C _i = 11 nF	C _i = 11 nF
Effective internal inductance	-	L _i = negligibly small	L _i = negligibly small
Galvanic isolation	Safe galvanic isolation from alarm option and basic device		
Test voltage	DC 840 V, 1 s		

7.5.3 SIA module

	Without Ex protection	With Ex protection Ex "ia"	With Ex protection Ex "ic", "ec", "t", "nA"
SIA module	6DR4004-8G	6DR4004-6G	6DR4004-6G
Limit encoder with slotted initiators and fault message output			
2 slotted initiators			
<ul style="list-style-type: none"> Binary output (limit transmitter) A1: Terminals 41 and 42 Binary output (limit transmitter) A2: Terminals 51 and 52 			
<ul style="list-style-type: none"> Connection 	2 wire technology in accordance with EN 60947-5-6 (NAMUR), for switching amplifiers connected on load side		
<ul style="list-style-type: none"> Signal state High (not triggered) 		> 2.1 mA	
<ul style="list-style-type: none"> Signal state Low (triggered) 		< 1.2 mA	
<ul style="list-style-type: none"> 2 slotted initiators 		Type SJ2-SN	
<ul style="list-style-type: none"> Function 		NC contact (NC, normally closed)	
<ul style="list-style-type: none"> Connecting to circuits with the following peak values 	Rated voltage 8 V, power consumption: ≥ 3 mA (limit not activated), ≤ 1 mA (limit activated)	U _i = DC 15 V I _i = 25 mA P _i = 64 mW	"ic": U _i = DC 15 V I _i = 25 mA "ec"/"nA": U _n ≤ DC 15 V P _n ≤ 64 mW
Effective internal capacitance	-	C _i = 161 nF	C _i = 161 nF
Effective internal inductance	-	L _i = 120 μH	L _i = 120 μH

	Without Ex protection	With Ex protection Ex "ia"	With Ex protection Ex "ic", "ec", "t", "nA"
1 fault message output			
• Binary output: Terminals 31 and 32			
• Connection	At switching amplifier in accordance with EN 60947-5-6: (NAMUR), $U_H = 8.2 \text{ V}$, $R_i = 1 \text{ k}\Omega$.		
• Signal state High (not triggered)	$R = 1.1 \text{ k}\Omega$	$> 2.1 \text{ mA}$	$> 2.1 \text{ mA}$
• Signal state Low (triggered)	$R = 10 \text{ k}\Omega$	$< 1.2 \text{ mA}$	$< 1.2 \text{ mA}$
• Auxiliary power U_H	$U_H \leq \text{DC } 35 \text{ V}$ $I \leq 20 \text{ mA}$	-	-
• Connecting to circuits with the following peak values	-	$U_i = \text{DC } 15 \text{ V}$ $I_i = 25 \text{ mA}$ $P_i = 64 \text{ mW}$	"ic": $U_i = \text{DC } 15 \text{ V}$ $I_i = 25 \text{ mA}$ "ec"/"nA": $U_n \leq \text{DC } 15 \text{ V}$ $P_n \leq 64 \text{ mW}$
Effective internal capacitance	-	$C_i = 5.2 \text{ nF}$	$C_i = 5.2 \text{ nF}$
Effective internal inductance	-	$L_i = \text{negligibly small}$	$L_i = \text{negligibly small}$
Galvanic isolation	The 3 outputs are galvanically isolated from the basic device.		
Test voltage	DC 840 V, 1 s		

7.5.4 Mechanical limit switch module

	Without Ex protection	With Ex protection Ex ia	With Ex protection Ex "ic", "t"
Mechanical limit switch module	6DR4004-8K	6DR4004-6K	6DR4004-6K
Limit encoder with mechanical switching contacts			
2 limit contacts			
• Binary output 1: Terminals 41 and 42			
• Binary output 2: Terminals 51 and 52			
• Max. switching current AC/DC	4 A	-	-
• For connecting to circuits with the following peak values	-	$U_i = 30 \text{ V}$ $I_i = 100 \text{ mA}$ $P_i = 750 \text{ mW}$	"ic": $U_i = 30 \text{ V}$ $I_i = 100 \text{ mA}$ "t": $U_n = 30 \text{ V}$ $I_n = 100 \text{ mA}$
Effective internal capacitance	-	$C_i = \text{negligibly small}$	$C_i = \text{negligibly small}$
Effective internal inductance	-	$L_i = \text{negligibly small}$	$L_i = \text{negligibly small}$

Technical data

7.5 Option modules

	Without Ex protection	With Ex protection Ex ia	With Ex protection Ex "ic", "t"
• Max. switching voltage AC/DC	250 V/24 V	DC 30 V	DC 30 V
1 fault message output			
• Binary output: Terminals 31 and 32			
• Connection	On switching amplifier according to EN 60947-5-6: (NAMUR), U _H = 8.2 V, R _i = 1 kΩ).		
• Signal state High (not triggered)	R = 1.1 kΩ	> 2.1 mA	> 2.1 mA
• Signal state Low (triggered)	R = 10 kΩ	< 1.2 mA	< 1.2 mA
• Auxiliary power	U _H ≤ DC 35 V I ≤ 20 mA	-	-
• Connecting to circuits with the following peak values	-	U _i = 15 V I _i = 25 mA P _i = 64 mW	"ic" : U _i = 15 V I _i = 25 mA "t": U _n = 15 V I _n = 25 mA
Effective internal capacitance	-	C _i = 5.2 nF	C _i = 5.2 nF
Effective internal inductance	-	L _i = negligibly small	L _i = negligibly small
Galvanic isolation	The 3 outputs are galvanically isolated from the basic device		
Test voltage	DC 3150 V, 2 s		
Rated condition height	Max. 2 000 m mean sea level Use a suitable power supply at an altitude of more than 2 000 m above sea level.	-	-

7.5.5 EMC filter module

	Without Ex protection	With Ex protection Ex "ia", "ic"	With Ex protection Ex "ec", "t", "nA"
The EMC filter module type C73451-A430-D23 is required to connect electro-sensitive external position measurement, e.g. NCS module type 6DR4004 or an external potentiometer type C73451-A430-D78 or 6DR4004-1ES.			
For devices without explosion protection, other types of potentiometers with a resistance of 10 kilohms can be connected.			
Maximum values when powered by the base unit with PA (6DR55) or FF communication (6DR56)	U _{max} = 5 V	U _o = 5 V I _o = 75 mA static I _o = 160 mA transient P _o = 120 mW C _o = 1 μF L _o = 1 mH	U _{max} = 5 V

	Without Ex protection	With Ex protection Ex "ia", "ic"	With Ex protection Ex "ec", "t", "nA"
Peak values when supplied by other basic devices (6DR50/1/2/3/9)	$U_{\max} = 5 \text{ V}$	$U_o = 5 \text{ V}$ $I_o = 100 \text{ mA}$ $P_o = 33 \text{ mW}$ $C_o = 1 \mu\text{F}$ $L_o = 1 \text{ mH}$	$U_{\max} = 5 \text{ V}$
Supply and signal power circuit	Galvanically connected with the basic device		

7.5.6 Internal NCS modules 6DR4004-5L and 6DR4004-5LE

Additional modules	Without Ex protection	With Ex protection Ex "ia"	With Ex protection Ex "ic", "ec", "t", "nA"
Internal NCS module	6DR4004-5L	6DR4004-5LE	6DR4004-5LE
Linearity (after corrections made by positioner)	$\pm 1 \%$	$\pm 1 \%$	$\pm 1 \%$
Hysteresis	$\pm 0.2 \%$	$\pm 0.2 \%$	$\pm 0.2 \%$

7.5.7 External position detection

7.5.7.1 Non contacting sensors 6DR4004-6N..0 and 6DR4004-8N..0

Additional modules	Without Ex protection	With Ex protection Ex "ia"	With Ex protection Ex "ic", "ec", "nA"
Travel range			
• Linear actuator 6DR4004-6/8N.20		3 to 14 mm (0.12 to 0.55")	
• Linear actuator 6DR4004-6/8N.30	10 to 130 mm (0.39 to 5.12"); up to 200 mm (7.87") on request		
• Part-turn actuator		30 to 100°	
Linearity (after corrections made by positioner)		$\pm 1 \%$	
Hysteresis		$\pm 0.2 \%$	
Temperature influence (range: rotation angle 120° or stroke 14 mm)	$\leq 0.1 \%/10 \text{ K}$ ($\leq 0.1 \%/18 \text{ }^\circ\text{F}$) for -20 to $+90 \text{ }^\circ\text{C}$ (-4 to $+194 \text{ }^\circ\text{F}$) $\leq 0.2\%/10 \text{ K}$ ($\leq 0.2\%/18 \text{ }^\circ\text{F}$) for -40 to $-20 \text{ }^\circ\text{C}$ (-40 to $-4 \text{ }^\circ\text{F}$)		
Climate class	According to IEC/EN 60721-3		
• Storage	1K5, but -40 to $+90 \text{ }^\circ\text{C}$ (-40 to $+194 \text{ }^\circ\text{F}$)		
• Transport	2K4, but -40 to $+90 \text{ }^\circ\text{C}$ (-40 to $+194 \text{ }^\circ\text{F}$)		
Vibration resistance			
• Harmonic oscillations (sine) according to IEC 60068-2-6	3.5 mm (0.14"), 2 to 27 Hz, 3 cycles/axis 98.1 m/s ² (321.84 ft/s ²), 27 to 300 Hz, 3 cycles/axis		
• Bumping according to IEC 60068-2-29	300 m/s ² (984 ft/s ²), 6 ms, 4000 shocks/axis		



Technical data

7.5 Option modules

Additional modules	Without Ex protection	With Ex protection Ex "ia"	With Ex protection Ex "ic", "ec", "nA"
Torque for cable gland nut made of	Plastic	Metal	Stainless steel
	2.5 Nm (1.8 ft lb)	4.2 Nm (3.1 ft lb)	4.2 Nm (3.1 ft lb)
Torque of hexagon socket-head screw M6x12 (shaft end or mounting bracket)		4 Nm (3 ft lb)	
Torque of hexagon socket head screw M6x25 (mounting console or mounting plate)		4 Nm (3 ft lb)	
Torque of hexagon socket head screw M3x12 (clamping ring)		1 Nm (0.7 ft lb)	
Housing protection type	IP68 according to IEC/EN 60529; NEMA 4X / Encl. Type 4X		
For connecting to circuits with the following peak values	-	U _i = 5 V I _i = 160 mA P _i = 120 mW	U _i = 5 V
Effective internal capacitance	-	C _i = 180 nF	C _i = 180 nF
Effective internal inductance	-	L _i = 922 µH	L _i = 922 µH

Certificates and approvals

CE conformity	The applicable directives and applied standards with their revision levels can be found in the EU declaration of conformity on the Internet.
---------------	--

Explosion protection Types of protection	Ex markings	
	ATEX/IECEX	FM/CSA
• Intrinsic safety "ia"	Zone 1:  II 2 G Ex ia IIC T6/T4 Gb	CI I Zn 1 AEx ib IIC IS CI I, II, III Div 1 Gp A-G
• Intrinsic safety "ic"	Zone 2:  II 3 G Ex ic IIC T6/T4 Gc	-
• Increased safety "ec" / non-sparking "nA"	Zone 2:  II 3 G Ex ec IIC T6/T4 Gc	CI I Zn 2 AEx nA IIC NI CI I Div 2 Gp A-D
Permissible ambient temperature	T4: -40 ... +90 °C (-40 ... +194 °F)	T4: -40 ... +85 °C (-40 ... +185 °F)
	T6: -40 ... +70 °C (-40 ... +158 °F)	T6: -40 ... +70 °C (-40 ... +158 °F)

7.5.7.2 External position detection system C73451-A430-D78 and 6DR4004-1ES

Ambient temperature	In hazardous areas, observe the maximum permissible ambient temperature corresponding to the temperature class.
• Perm. ambient temperature for operation	-40 ... +90 °C (-40 ... +194 °F)
Degree of protection ¹⁾	IP66 to IEC/EN 60529 / NEMA 4X
Climate class	According to IEC/EN 60721-3
• Storage	1K5, but -40 ... +90 °C (1K5, but -40 ... +194 °F)

Ambient temperature	In hazardous areas, observe the maximum permissible ambient temperature corresponding to the temperature class.
• Transport	2K4, but -40 ... +90 °C (2K4, but -40 ... +194 °F)
• Operation	4K3, but -40 ... +90 °C (4K3, but -40 ... +194 °F)

¹) Impact energy max. 1 joule.

Construction

How does it work?	
• Range of stroke (linear actuator)	3 to 130 mm (0.12 ... 5.12") (angle of rotation of the positioner shaft 16 to 90°)
• Angle of rotation (part-turn actuator)	30 to 100°

Mounting method	
• On the linear actuator	Using mounting kit 6DR4004-8V and, where necessary, an additional lever arm 6DR4004-8L on actuators according to IEC 60534-6-1 (NAMUR) with a fin, columns, or a plane surface.
• On the part-turn actuator	Using mounting kit 6DR4004-8D on actuators with mounting plane according to VDI/VDE 3845 and IEC 60534-6-2: The required mount must be provided on the actuator-side.



Material	
• Enclosure C73451-A430-D78	Glass-fiber reinforced polycarbonate (PC)
• Enclosure 6DR4004-1ES	Aluminum

Weight	
• Enclosure C73451-A430-D78	Approx. 0.9 kg (1.98 lb)
• Enclosure 6DR4004-1ES	Approx. 1.6 kg (3.53 lb)



Torque for cable gland nut made of plastic	See Construction (Page 70)
--	----------------------------

Electrical data	
For connecting to circuits with the following peak values	$U_i = 5 \text{ V}$ $I_i = 100 \text{ mA}$ $P_i = 160 \text{ mW}$ $C_i = \text{negligibly small}$ $L_i = \text{negligibly small}$

Certificates and approvals	
CE conformity	The applicable directives and applied standards with their revision levels can be found in the EU declaration of conformity on the Internet.

Explosion protection	Ex markings	
Explosion protection in accordance with	ATEX/IECEx	FM/CSA
C73451-A430-D78: Intrinsic safety "I", "IS"	 II 2 G Ex ia IIC T6/T4 Gb  II 3 G Ex ic IIC T6/T4 Gc	CI I Zn 1 AEx ib IIC IS CI I Div 1 Gp A-D

7.5 Option modules

Explosion protection	Ex markings	
6DR4004-1ES: Intrinsic safety "i", "IS" and for use in Zone 2 / DIV.2: "ec", "nA", "ic"	 II 2 G Ex ia IIC T6/T4 Gb  II 3 G Ex ic IIC T6/T4 Gc  II 3 G Ex ec IIC T6/T4 Gc	CI I Zn 1 AEx ib IIC IS CI I, II, III Div 1 Gp A-G Zn 21 AEx ib Db IIIC T110°C CI I Zn 2 AEx nA IIC NI CI I Div 2 Gp A-D
Permissible ambient temperature	T4: -40 ... +90 °C (-40 ... +194 °F) T6: -40 ... +60 °C (-40 ... +140 °F)	

Appendix

8.1 Certificates

You can find certificates on the Internet at Certificates (<http://www.siemens.com/processinstrumentation/certificates>) or on an included DVD.

8.2 Technical support

Technical Support

If this documentation does not provide complete answers to any technical questions you may have, contact Technical Support at:

- Support request (<http://www.siemens.com/automation/support-request>)
- More information about our Technical Support is available at Technical support (<http://www.siemens.com/automation/csi/service>)

Internet Service & Support

In addition to our documentation, Siemens provides a comprehensive support solution at:

- Service&Support (<http://www.siemens.com/automation/service&support>)

Personal contact

If you have additional questions about the device, please contact your Siemens personal contact at:

- Partner (<http://www.automation.siemens.com/partner>)

In order to find the contact for your product, select under 'All Products and Branches' the path 'Automation Technology > Sensor Systems'.

Documentation

You can find documentation on various products and systems at:

- Instructions and manuals Instructions and manuals (<http://www.siemens.com/processinstrumentation/documentation>)

See also

SIPART PS2 product information (<http://www.siemens.com/sipartps2>)

E-mail (<mailto:support.automation@siemens.com>)

Process instrumentation catalog (<http://www.siemens.com/processinstrumentation/catalogs>)

8.3 Accessory part sealing plug / thread adapter

8.3.1 Intended use of accessory part

The sealing plug and the thread adapter (components) can be used for installation in electrical equipment of flameproof "Ex d" type of protection of groups IIA, IIB, IIC as well as dust protection by enclosure "Ex t" type of protection.

8.3.2 Safety instructions for accessory part

 WARNING
<p>Incorrect assembly</p> <ul style="list-style-type: none"> • The component can be damaged or destroyed or its functionality impaired through incorrect assembly. <ul style="list-style-type: none"> – Mount the component using a suitable tool. Refer to the information in Chapter "Technical specifications of accessory part (Page 91)", for example, torques for installation. • For "Explosion-proof Ex d" type of protection: To ensure an engagement depth of 8 mm, the enclosure must have a wall thickness of at least 10 mm. <p>Improper modifications</p> <p>Danger to personnel, system and environment can result from modifications and repairs of the component, particularly in hazardous areas.</p> <ul style="list-style-type: none"> • Any modification which deviates from the delivery state is not permitted. <p>Loss of enclosure type of protection</p> <p>IP protection is not guaranteed without sealant.</p> <ul style="list-style-type: none"> • Use a suitable thread sealant. • If you are using the component in type of protection dust protection by enclosure "Ex t", use the supplied sealing ring (①, figure in Chapter "Dimensional drawings of accessory part (Page 92)"). <p>Unsuitable fluids in the environment</p> <p>Danger of injury or damage to device.</p> <p>Aggressive media in the environment can damage the sealing ring. Type of protection and device protection may no longer be guaranteed.</p> <ul style="list-style-type: none"> • Make sure that the sealing material is suitable for the area of use.

Note

Loss of type of protection

Changes in the ambient conditions can loosen the component.

- As part of the recommended maintenance intervals: Check the compression fitting for tight fit and tighten, if necessary.

8.3.3 Technical specifications of accessory part

Technical specifications sealing plug and thread adapter	
Sealing plug suitable for types of protection	Explosion-proof enclosure "d" of groups IIA, IIB, IIC Dust protection by enclosure "t"
Standard compliance	The components meet Guideline 94/9. They meet the requirements of standards IEC/EN 60079-0; IEC/EN 60079-1; IEC/EN 60079-31.

8.3 Accessory part sealing plug / thread adapter

Technical specifications sealing plug and thread adapter	
Explosion protection	
• Gas explosion protection	II2G Ex d IIC
• Dust explosion protection	II1D Ex t IIIIC
Certificates	
	IECEX TUN 13.0022 U TÜV 13 ATEX 121710 U
Material for sealing plug / thread adapter	Stainless steel
Material for seal	Vulcanized fiber or Victor Reinz AFM 30
Degree of protection	IP66 in accordance with IEC 60529
Ambient temperature range	-40 ... +100 °C (-40 ... +212 °F)
For "Ex d" type of protection:	
Required wall thickness for tappings	10 mm
Torque	
• For thread size M20 x 1.5	65 Nm
• For thread size M25 x 1.5	95 Nm
• For thread size ½-14 NPT	65 Nm
Width A/F for thread size M20 x 1.5	27
Width A/F for thread size M25 x 1.5	30
Key size for thread size ½-14 NPT	10

8.3.4 Dimensional drawings of accessory part

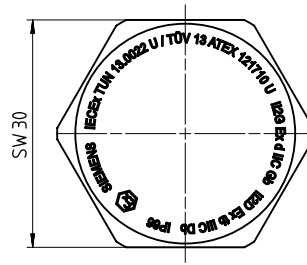
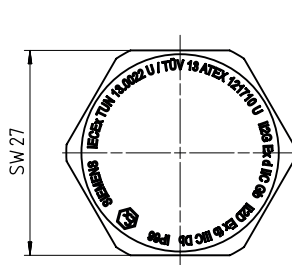
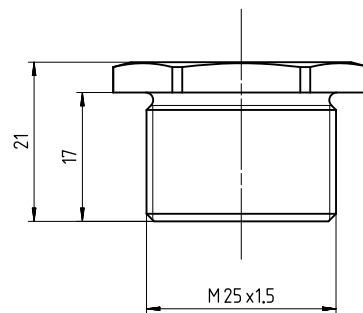
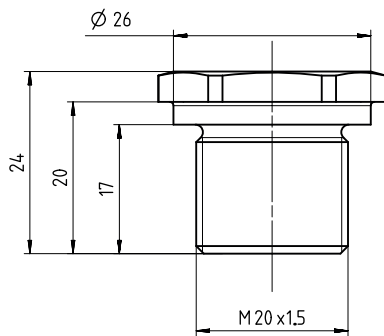

Sealing plug Ex d, M20 x 1.5, dimensions in mm

Sealing plug Ex d, M25 x 1.5, dimensions in mm

Index

A

Article number
on the nameplate, 11
Attenuator, 75

C

Carrier, 54
Carrier pin, 57
Certificates, 15
Commissioning
Automatically, 56, 59
Cancel, 58, 61
Interrupting, 56
Compressed air, 20
Connecting
SIA module, 39
Connection
Pneumatic, 45, 54
Control air outlet, 75
Correct usage, (See improper device modifications)
Customer Support Hotline, 89

E

Enclosure ventilation, 75
Ex markings, 73, 86, 87, 88
Exhaust air outlet, 75, 76

F

Factory setting
Resetting to ~, 56, 59
Flow rate, 76
Friction clutch, 26

H

Hazardous area
Laws and directives, 15
Hotline, 89

I

Improper device modifications, 16
Initialization, (Commissioning)
Interrupting, 59
Internal NCS module
Installation, 24
Technical specifications, 85
Internet, 89

L

Linear actuator
Automatic commissioning, 56

M

Mechanical limit switch module, 51

N

Natural gas
Maximum values for ventilation, 75
Operation, 51
NCS
Installation, 24
NCS module
Internal, 24

O

Operation
Natural gas, 51
Order code, 11
Ordering supplement, 11

P

Parameters 1 to 5
Overview, 53
Part-turn actuator
Automatic commissioning, 59
Pneumatic block, (See pneumatic block)
Purging air selector, 54
Pneumatic connections, 54

Position feedback module, 39
Product name, 11
Purge air switch, 75
Purging air selector, 54

Q

Qualified personnel, 17

S

Scope of delivery, 11
Screen
 Cleaning of~, 64
Service, 89
SIA module
 Connecting, 39
Slot initiator, (See SIA module)
Support, 89
Symbols, (Refer to warning symbols)

T

Terminal strip, 54
Test certificates, 15

W

Warning symbols, 15

Get more information

www.siemens.com/processautomation
www.siemens.com/processinstrumentation

Siemens AG
Process Industries and Drives
Process Automation
76181 Karlsruhe
GERMANY

Subject to change without prior notice
A5E03436620-AC
© Siemens AG 2017



A5E03436620



A5E03436620

www.siemens.com/automation